

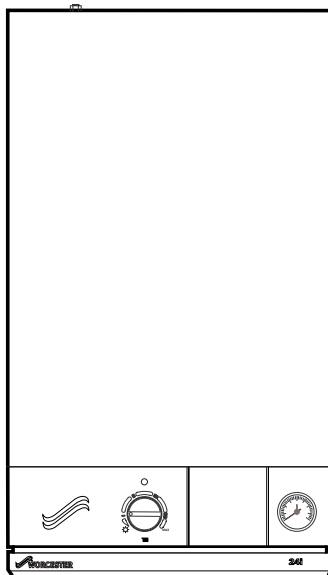

24i RSF

WALL MOUNTED COMBINATION BOILER FOR CENTRAL HEATING
AND MAINS FED DOMESTIC HOT WATER

INSTALLATION AND SERVICING INSTRUCTIONS



GC NUMBERS

N.G. 47 311 37 L.P.G. 47 311 38



Worcester Bosch supports the
Benchmark code of practice

BOILER OUTPUT

To Domestic Hot Water – Modulated Control

Minimum 7.5 kW (25,600 Btu/h)

Maximum 23.4 kW (80,000 Btu/h)

To Central Heating – Modulated Control\

Auto Range Rated

Minimum 7.5 kW (25,600 Btu/h)

Maximum 23.4 kW (80,000 Btu/h)

THESE INSTRUCTIONS APPLY IN THE UK ONLY

THESE INSTRUCTIONS ARE TO BE LEFT WITH THE USER OR AT THE GAS METER

**This appliance must be installed by a competent person in accordance
with the Gas Safety (Installation and Use) Regulations 1998**

Contents

1. Installation Requirements	Page 2
2. General Information	Page 2
3. Data Tables	Page 4
4. Siting the Appliance	Page 5
5. Siting the Flue	Page 6
6. Air Supply	Page 6
7. Sealed System	Page 7
8. Open Vent System	Page 7
9. Hot Water Supply	Page 8

10. Electrical	Page 9
11. Installing the Appliance	Page 11
12. Commissioning the Appliance	Page 16
13. Instructions to the User	Page 18
14. Inspection and Service	Page 18
15. Replacement of Parts	Page 20
16. Conversion Instructions	Page 23
17. Operational Flow Diagrams	Page 24
18. Fault Finding	Page 26
19. Component Parts List	Page 34

1. Installation Regulations

1.1 Gas Safety (Installation and Use) Regulations, October 1994 all gas appliances must be installed by a competent person in accordance with the above regulations. Failure to install appliances correctly could lead to prosecution.

1.2 The manufacturers notes must not be taken, in any way, as overriding statutory obligations.

1.3 The compliance with a British Standard does not, of itself, confer immunity from legal obligations. In particular the installation of this appliance must be in accordance with the relevant requirements of the following:

Gas Safety (Installation and Use) Regulations 1998 as amended.

Current IEE Wiring Regulations BS 7671.

Local Building Regulations.

Building Standards (Scotland)(Consolidation).

Bylaws of the local Water Company.

Health and Safety Document No. 635 (Electricity at Work Regulations).

The British Gas Material and Installation Specification for central heating and hot water

It should be in accordance with the relevant recommendations of the following British Standards.

BS6798:1987 Specification for installation of gas fired hot water boilers of rated input not exceeding 60 kW.

BS5449:1990 Central Heating for Domestic Premises.

BS5546:1990 Installation of gas hot water supplies for domestic purposes.

BS5440:1:2000 Flues and Ventilation for gas appliances of rated input not exceeding 60 kW: Flues.

BS5440:2:2000 Flues and Ventilation for gas appliances of rated input not exceeding 70kW: Air Supply.

BS6891:1988 Installation of low pressure gas pipework installations up to 28mm (R1).

BS7593:1993 Central Heating system cleansing and flushing.

BS5482:PART 1 Domestic Butane and Propane gas burning installations in permanent dwellings.

1.5 CARAVAN AND HOLIDAY HOMES

The installation must meet the following standards.

BS5482:2 LPG and EN721 ventilation.

1.6 PARK HOMES AND RESIDENTIAL

The installation must meet the following standards.

BS5482:1 LPG and BS3632 ventilation.

1.7 To ensure that the installation will perform to the highest standards, the system and components should conform to any other relevant British Standards in addition to those mentioned in the instructions.

1.8 The appliance complies with the Essential Requirements of the Gas Appliance Directive and other Directives currently applicable.

1.9 This appliance contains no asbestos products.

There is no potential hazard due to the appliance being electrically unsafe.

There are no substances used that are a potential hazard in relation to the COSHH Regulations 1988.

1.10 The advice and instructions given in this document covers, as far as possible, the foreseeable situations which may arise. Contact Worcester Heat Systems Technical Helpline for advice on specific installations.

2. General Information

(benchmark) The **Benchmark** initiative is the new code of practice to encourage the correct installation, commissioning and servicing of domestic central heating boilers and system equipment.

The 'Log-book' is a vital document that must be completed by the installer at the time of installation. It confirms that the boiler has been installed and commissioned according to the manufacturers instructions.

Without the completion of the Log-book, manufacturers may refuse to respond to a call-out from a householder, who will be advised that he or she must call back the installer, who has not fulfilled his obligations to record the information required by the initiative.

It is important that:

The services and the system are properly flushed as specified.

The User is clearly instructed on the correct operation of the appliance.

The benefits of regular servicing are explained - to maintain the efficiency and extend the life of the appliance.

2.1 This appliance is not suitable for external installation.

2.2 The appliance controls are set to provide a maximum output of 23.4 kW for the domestic hot water and central heating load.

2.3 The control circuit provides direct burner ignition. A pilot is not used.

2.4 PRINCIPAL APPLIANCE COMPONENTS.

See Fig. 1.

Fig. 1. Water flow diagram.

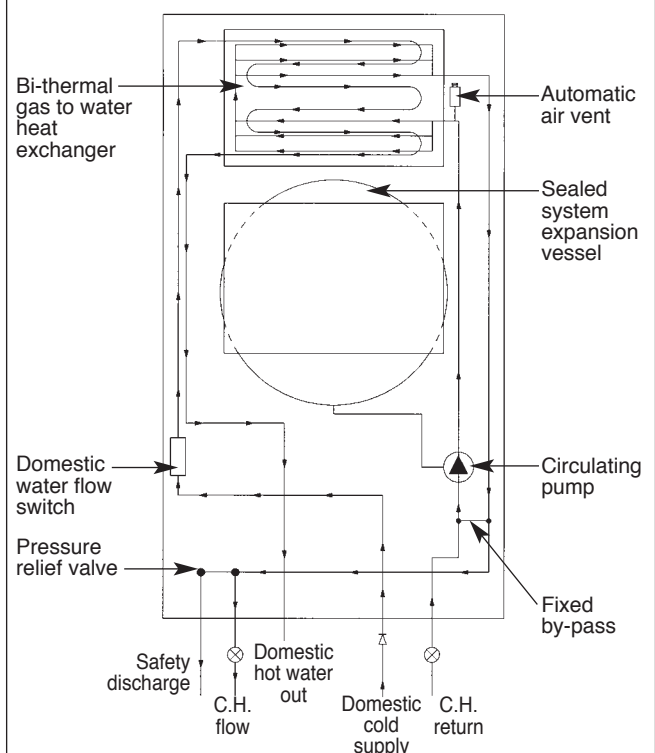

A low thermal capacity Gas to Water heat exchanger incorporating an integral Hot Water heat exchanger to provide domestic hot water.

Fully modulating controls in the central heating and domestic hot water modes of operation.

An expansion vessel, pressure gauge and pressure relief valve.

A fixed by-pass for the central heating system.

A Temperature safety cut-out control.

A water flow regulator.

A standard telescopic horizontal flue assembly giving flue lengths from 330mm to 725mm.

Optional extra extension flue kits to provide for flue lengths up to 2500mm.

An optional vertical flue kit to provide for flue lengths up to 3400mm including vertical flue terminal.

Optional fascia mounted mechanical programmer.

2.5 ELECTRICAL SUPPLY

Mains supply: 230V ~, 50 Hz, 180 watts.

External fuse: 3A., Internal fuses: 2AT HRC(F1), and 1 AF (F2).

	Total length of gas supply pipe (metres)				Pipe size (Ømm)
	3	6	9	12	
Gas Discharge Rate (m ³ /hr)	Propane				
	1.5	–	–	–	15
	8.0	5.2	4.2	3.6	22
	15.9	8.8	8.5	7.2	28
	Natural Gas				
	8.7	5.8	4.6	–	22
	18.0	12.0	9.4	–	28

2.6 GAS SUPPLY

The boiler requires 2.76 m³/h (97.5 ft³/hr) of natural gas with a calorific value of 37.78 MJ/m³ (1014 Btu/ft³) or 1.07 m³/h (37.8 ft³/hr) of propane with a calorific value of 95.65 MJ/m³ (2568 Btu/ft³). The meter governor should deliver a dynamic pressure of 20 mbar (8in w.g.) at the appliance, equivalent to a pressure of about 19-19.5 mbar at the gas valve on natural gas or 37.0 mbar (14.8in w.g.) at the appliance for propane.

The gas meter and supply pipes must be capable of supplying this quantity of gas in addition to the demand from any other appliances being served. The table below gives an indication of limiting gas pipe lengths and the allowance to be made for fittings. Refer to BS6891 for further information.

The complete installation, including the gas meter, must be tested for soundness and purged. Refer to BS 6891.

Note: Each fitting used in the gas line from the meter is equivalent to a length of straight pipe which must be added to the straight pipe length to give the total length.

i.e.: Bend = 0.5 metres, Tee = 0.5 metres, 90° Bend = 0.3 metres.

2.7 PACKING

The appliance and flue components are packaged separately.

2.8 GENERAL INSTALLATION

The appliance is for connection to a sealed system only.

The specified ventilation openings made into a wall or compartment door must not be obstructed.

If the appliance is to be fitted into a compartment then the compartment must conform to the requirements of BS 6798: 1987: Section 7.

Do not place anything on top of the appliance.

The clearances specified for servicing must be maintained.

2.9 FLUE

The appliance has a multi-directional fanned flue system.

The standard telescopic flue assembly length is from 330mm to 725mm.

Extension flue kits are available for flue lengths up to 2500mm.

An optional vertical flue kit to provide for flue lengths up to 3400mm including vertical flue terminal.

A terminal guard, Type K2, GC 393 553, is available from Tower Flue Components, Vale Rise, Tonbridge, TN9 1TB.

Do not allow the flue terminal fitted to the outside wall to become obstructed or damaged.

A kit for internal fixing of the flue is available separately.

2.10 CONTROLS

The electronic control system and gas valve modulate the heat input in response to the domestic hot water temperature and central heating setting between minimum and maximum.

The Central Heating Temperature control knob provides for the selection of domestic hot water only (Turned fully anti-clockwise) or central heating and domestic hot water (Turned clockwise).

A fascia mounted programmer is provided as an optional extra. A remote mounted programmer may be connected to the appliance.

There is provision for the connection of a mains voltage room thermostat and/or a frost thermostat.

The electronic controls prevent rapid cycling of the appliance in the central heating mode.

2.11 SYSTEM NOTES

IMPORTANT *(benchmark)*

Check that no dirt is left in either the gas or water pipework as this could cause damage to the appliance. The heating system should be flushed and treated in accordance with the recommendations of BS 7593:1992. Thoroughly flush cold water mains supply and purge the gas supply before finally connecting the appliance.

The water pipe connections throughout a sealed system must be capable of sustaining a pressure of up to 3 bar.

Radiator valves must conform to the requirements of BS 2767:1991.

The relief valve discharge must be directed away from any electrical components or where it would cause a hazard to the user.

A drain cock to BS 2879 must be fitted to the lowest point of the system. For circuit design purposes it is important that due note is taken of the information given in Table 3, section 3 relating to the available pump head.

2.12 SHOWERS, BIDETS, TAPS AND MIXING VALVES

Hot and cold taps and mixing valves used in the system must be suitable for operating at mains pressure.

Thermostatically controlled shower valves will guard against the flow of water at too high a temperature.

Hot and cold mains fed water can be supplied direct to an over-rim flushing bidet subject to local Water Company requirements.

With all mains fed systems the flow of water from the individual taps will vary with the number of outlets operated simultaneously and the cold water mains supply pressure to the property. Flow balancing using "Ball-o-Fix" type valves is recommended to avoid an excessive reduction in flow to individual outlets.

2.13 SAFETY CONSIDERATIONS

The appliance must not be operated in a waterless condition.

The appliance must not be operated with the boiler inner casing cover removed.

Work must not be carried out on the appliance without the gas and electricity supplies being switched off.

Checks must be made to ensure that the ventilation openings made into walls and partitions are unobstructed and the correct size.

IMPORTANT: Where back-flow prevention devices, including water meters, are fitted the expansion of hot water into cold water main can be prevented. This can result in a pressure build-up that may cause damage to the boiler and household devices such as showers, washing machines etc.

In these cases we recommend that a mini-expansion vessel be fitted adjacent to the boiler in the cold water pipe.

2.14 OPERATION

Domestic Hot Water: With a demand for hot water the burner will light at its maximum setting and then automatically adjust its output to maintain the temperature of the delivered water. When hot water is no longer required, the burner will extinguish. The fan and pump may continue to run for a short period to dissipate the residual heat from the appliance.

Central Heating: With a demand for heating the burner will light at its minimum setting and gradually increase to give a controlled temperature rise. When the required heating temperature is achieved the output of the appliance is then automatically adjusted to maintain the temperature of the system. The output can reduce down to a minimum of 7.5 kW. If the system no longer requires even the minimum output to maintain the desired room temperature the burner will extinguish. The fan and pump may continue to run to dissipate the residual heat from the appliance. The appliance will remain off for a fixed period before re-lighting to automatically meet the system requirements.

Domestic Hot Water and Central Heating: The appliance will supply heat to the central heating system as required. A demand for domestic hot water at a tap or shower will override the central heating requirement for the period of the domestic hot water demand. When hot water is no longer required the appliance will return to the central heating state and its normal mode of operation. The fan may continue to run to dissipate the residual heat from the appliance as necessary.

2.15 DOMESTIC SUPPLY

Devices capable of preventing the flow of expansion water must not be fitted unless separate arrangements have been made.

3. Data Tables

The data plate is fixed to the inner casing cover.

Table 1

NOMINAL BOILER RATINGS							
OUTPUT		INPUT (Net).		BURNER SETTING PRESSURE		GAS RATE	
kW	Btu/h	kW	Btu/h	m bar.	in. wg.	m ³ /h	ft ³ /h
NATURAL GAS							
7.5	(25,600)	9.60	(32,750)	1.0	0.4	1.01	35.7
23.4	(80,000)	26.05	(88,890)	13.6	5.4	2.76	97.5
PROPANE							
7.5	(25,600)	9.60	(32,750)	3.5	1.4	0.39	13.9
23.4	(80,000)	26.05	(88,890)	35.0	14.0	1.07	37.8

Table 2.

FLUE DETAILS	
HORIZONTAL FLUE (Side or Rear)	mm
FLUE DIAMETER	100
WALL HOLE DIAMETER	110
WALL HOLE DIAMETER (using internal flue fitting kit)	150
STANDARD FLUE – MINIMUM LENGTH	330/425*
STANDARD FLUE – MAXIMUM LENGTH	725
EXTENDED FLUE – MAXIMUM LENGTH	2500

*NOTE: Flue lengths between 330 and 425 require the flue to be cut.

Table 3

AVAILABLE PUMP HEAD						
BOILER OUTPUT		HEAD		MIN. FLOW RATE		TEMPERATURE RISE ACROSS HEATING FLOW AND RETURN
kW	Btu/h	Metres	Feet	L/min.	Gal/Min.	
7.5	(25,600)	6.0	19.7	9.8	2.2	11°C (20°F)
23.4	(80,000)	2.6	8.5	30.5	6.7	

Table 4

SPECIFICATIONS	
CENTRAL HEATING FLOW FITTING	22mm Compression
CENTRAL HEATING RETURN FITTING	22mm Compression
COLD WATER MAINS INLET FITTING	15mm Compression
DOMESTIC HOT WATER OUTLET FITTING	15mm Compression
GAS INLET FITTING	Rc ½inch
PRESSURE RELIEF VALVE DISCHARGE FITTING	15 mm Copper Tube
OVERALL HEIGHT (including flue turret)	960mm (37.8 inches)
CASING HEIGHT	800mm (31.5 inches)
CASING WIDTH	450mm (17.7 inches)
CASING DEPTH	360mm (14.2 inches)
WEIGHT(including water)	44 kg
INSTALLATION WEIGHT	39 kg
PACKAGED WEIGHT	44 kg
PRIMARY WATER CAPACITY	3.0 litres
MAXIMUM COLD SUPPLY PRESSURE	10 Bar (150 psi)
MINIMUM COLD SUPPLY PRESSURE (working) for max. hot water flow	0.9 bar
MINIMUM COLD SUPPLY PRESSURE (working) to operate appliance	0.1 bar
MAXIMUM CENTRAL HEATING FLOW TEMPERATURE	Nominally 82°C (180°F)
OUTPUT TO DOMESTIC HOT WATER	Modulating 7.5 to 23.4 kW
OUTPUT TO CENTRAL HEATING	Modulating 7.5 to 23.4 kW
MAXIMUM DOMESTIC HOT WATER FLOW RATE (from the appliance)	Nominally 8.0 ± 15% litres/min
EQUIVALENT DOMESTIC HOT WATER FLOW RATE TO GIVE A TEMP RISE OF 30°C (SPECIFIC RATE)	Nominally 11.2 litres/min
SEDBUK	78.3% D

4. Siting The Appliance

4.1 The appliance may be installed in any room although particular attention is drawn to the requirements of the current IEE Wiring Regulations BS 7671 and, in Scotland, the electrical provisions of the Building Regulations applicable in Scotland, with respect to the installation of appliances in rooms containing baths or showers.

Where a room sealed appliance is installed in a room containing a bath or shower, any electrical switch or appliance control using mains electricity must not be able to be touched by a person using the bath or shower.

4.2 The appliance is not suitable for external installation.

4.3 The appliance does not require any special wall protection.

4.4 The wall must be capable of supporting the weight of the appliance. See Table 4.

4.5 The following clearances must be available for installation and for servicing. See Fig. 2. (note the clearances at the front are for a removable panel e.g. a door).

4.6 The appliance can be installed in a cupboard used for airing clothes provided that the requirements of BS 6798 and BS 5440:2 are strictly followed.

Above turret	30mm
In front to a fixed surface	600mm
Below	200mm
Right-hand side	10 mm
Left-hand side	10 mm

Notwithstanding the instructions given in BS 5440:2, this appliance may be fitted in a compartment with no vents as long as the minimum clearances stated in Section 6: Air Supply, are maintained.

4.7 The airing space must be separated from the boiler space by a perforated non-combustible partition. Expanded metal or rigid wire mesh are acceptable provided that the major dimension is less than 13mm. See BS 6798:1987.

4.8 No combustible surface must be within 75mm of the casing. See BS476:4.

4.9 Always consider the possible need to disconnect the pipes from the appliance after installation.

4.10 **LPG Installation: The appliance shall not be installed in a room or internal space below ground level when it is intended for use with LPG. This does not preclude the installation into rooms which are basements with respect to one side of the building but open to ground level on the opposite side.**

Fig. 2. Appliance casing dimensions and required clearances.

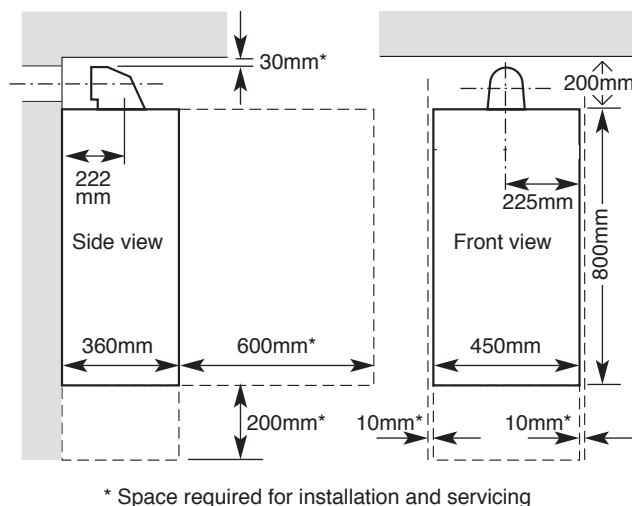

5. Siting The Flue

See Fig. 3.

5.1 The flue must be installed as specified in BS 5440:Part 1.

5.2 The terminal must not cause an obstruction nor the discharge cause a nuisance.

5.3 If a terminal is fitted less than 2 metres above a surface to which people have access then a guard must be fitted. See Section 2.9.

5.4 The terminal guard must be evenly spaced about the flue terminal and fixed to the wall using plated screws.

5.5 In certain weather conditions a terminal may steam and siting where this could cause a nuisance should be avoided.

5.6 Take care to ensure that combustion products do not enter ventilated roof voids.

6. Air Supply

6.1 The appliance does not require a separate vent for combustion air.

6.2 The appliance can be fitted in a cupboard with no vents for cooling but the minimum clearances must be increased to those given below (note the clearances at the front are for a removable panel e.g. a door).

Above the Turret	30mm
In front	250mm
Below	200mm
Right-hand side	75mm
Left-hand side	75mm

6.3 If the appliance is to be fitted in a cupboard or compartments with less clearance than those above (minimum clearances given in Section 4. Siting The Appliance) then permanent vents for cooling are required. One at high level and one at low level, either direct to outside air or to a room. Both vents must pass to the same room or be on the same wall to the outside air.

6.4 The minimum free areas required are given below.

6.5 Refer to BS 6798 and BS 5440:2 for additional information.

POSITION OF AIR VENTS	AIR FROM THE ROOM	AIR DIRECT FROM OUTSIDE
HIGH LEVEL	270cm ²	135cm ²
LOW LEVEL	270cm ²	135cm ²

Fig. 3. Siting of the flue terminal.

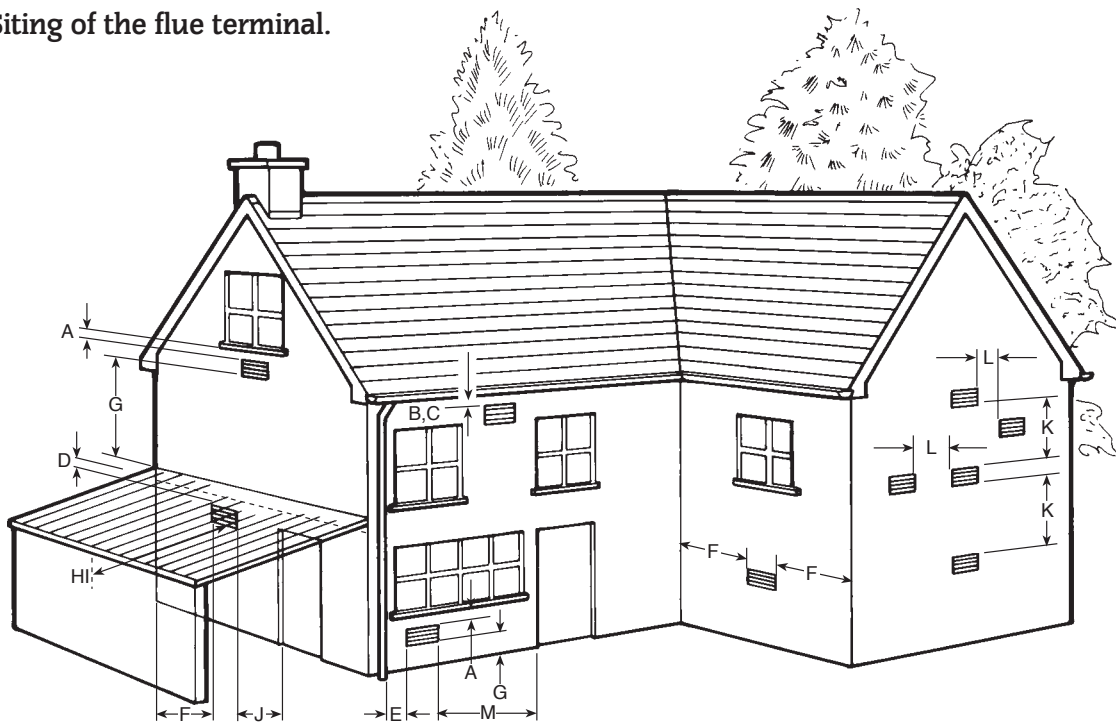

TERMINAL POSITION	MIN. DISTANCE	TERMINAL POSITION	MIN. DISTANCE
A- directly below an openable window or other opening e.g. air brick.	300mm	I- From a terminal facing a terminal	1200mm
B- Below gutters, soil pipes or drain pipes.	75mm	J- From an opening in a car port (e.g. door window) into dwelling.	1200mm
C- Below eaves.	25mm	K- Vertically from a terminal on the same wall.	1500mm
D- Below balconies or car port roof.	25mm	L- Horizontally from a terminal on the same wall.	300mm
E- From vertical drain pipes and soil pipes.	25mm	M- From door, window or air vent.	300mm
F- From internal or external corners.	25mm		
G- Above ground, roof or balcony level.	300mm		
H- From a surface facing a terminal.	600mm		

7. Sealed System

See Figs. 4.

7.1 The system must comply with the requirements of BS 6798 and BS 5449.

7.2 The appliance must not be operated without the system being full of water, properly vented and pressurised.

7.3 The pressure relief valve operates at 3 bar (45lb/in²). The discharge must be directed away from electrical components or where it might be a hazard to the user.

7.4 The pressure gauge indicates the system pressure which must be maintained.

7.5 The 8 litre expansion vessel is charged to 0.5 bar and is suitable for a static head of 5 metres (17.5ft). The pressure can be increased if the static head is greater than 5 metres (17.5ft).

7.6 With an initial system pressure of 0.5 bar, a system capacity of up to 100 litres can be accommodated. For system capacities greater than this an extra expansion vessel must be fitted. Refer to BS 7074 Pt. 1 for more information. The charge pressure can be increased but with a consequent decrease in system volume.

7.7 The filling point must be at low level. See Fig. 4.

7.8 Water loss must be replaced. See Fig 4. The connection should be made in the central heating return as close to the appliance as possible. A filling loop kit is supplied.

7.9 Repeated venting loses water from the system. It is essential that this water is replaced and the system pressure maintained.

7.10 Connections to the mains water supply must not be made without the authority of the local Water Company.

7.11 The pump is set at maximum and must not be adjusted.

7.12 Connections in the system must sustain a pressure of up to 3 bar.

7.13 Radiator valves must conform to BS 2767:10.

7.14 Other valves used should conform to the requirements of BS 1010.

7.15 The appliance is fitted with a fixed internal by-pass. But it is advisable to keep one radiator permanently open.

8. Open Vent System

The appliance is **NOT** suitable for connection to an open vented system.

Fig. 4. Sealed primary water system.

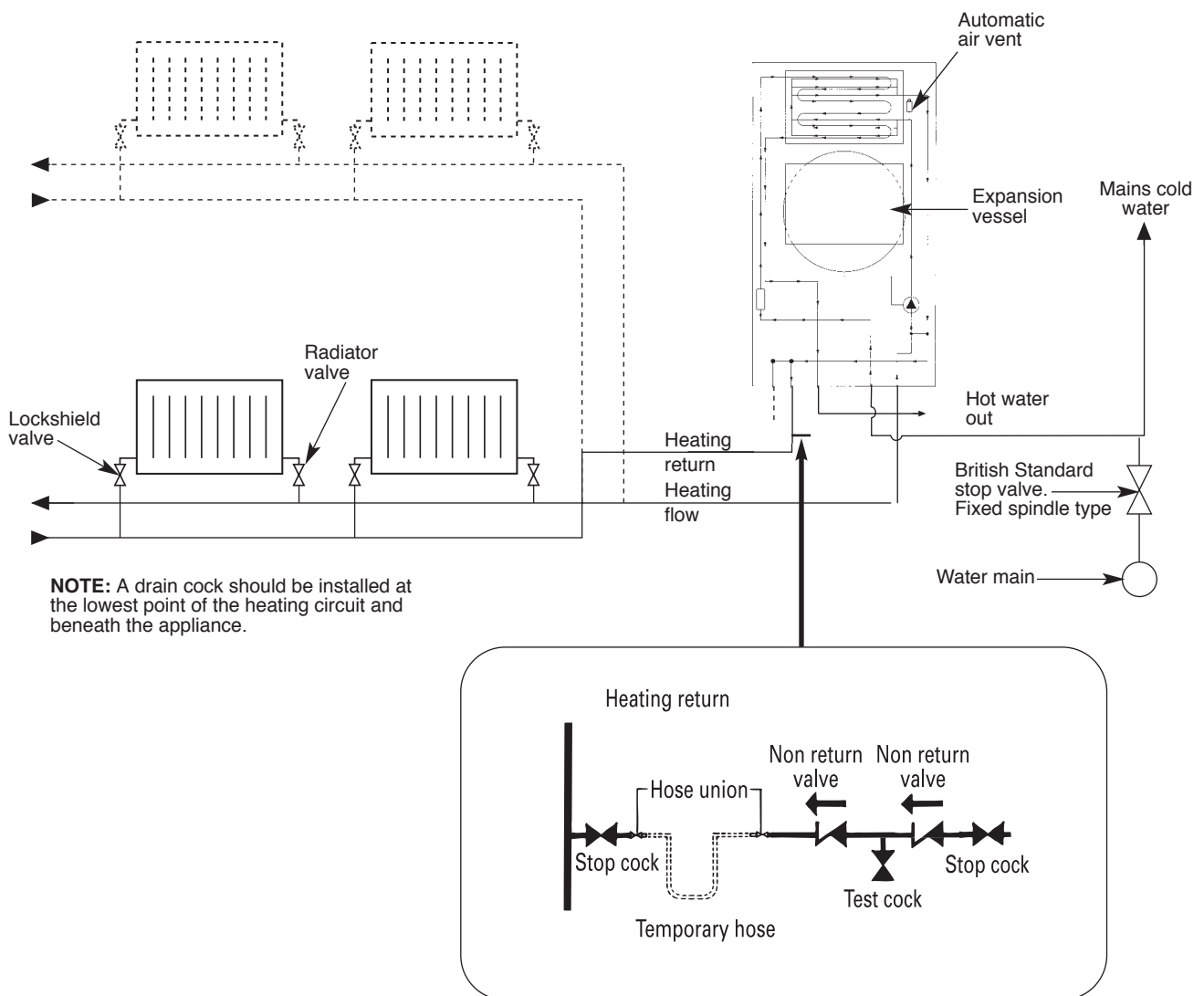

9. Hot Water Supply

9.1 The following are general requirements and, if necessary, reference should be made to the local Water Company before fitting the appliance.

9.2 **MAINS COLD WATER INLET.** Devices capable of preventing the flow of expansion water must not be fitted unless separate arrangements have been made.

A mini expansion vessel kit is available which contains the necessary parts for fitting an internal expansion vessel to the appliance.

See Section 19 COMPONENT PARTS LIST.

A thread sealant compatible with potable water must be used. An external expansion vessel may be fitted on the mains cold water connection to the appliance.

9.3 The final 600mm of the mains cold water connection to the appliance should be made in copper tube only.

9.4 The appliance is suitable for a mains pressure of up to 10 bar (150 lb/in²).

9.5 The appliance is fitted with a mains supply isolating valve.

9.6 The maximum domestic hot water flow rate is 9.4 litres/min ($\pm 15\%$) (1.8 gallons/min).

9.7 In winter (when the mains inlet water temperature is lower) a reduced flow rate at the taps may be required to achieve the type of hot water delivery temperature available in warmer weather.

9.8 It is suggested that long pipe runs to the taps or shower should be insulated to prevent the rapid cooling of domestic hot water after a tap or shower has been turned off.

9.9 Hot and cold taps and mixing valves used with this appliance must be suitable for operating at mains pressure and temperatures of 65°C.

9.10 No anti-siphonage arrangements are necessary except for some loose head showers. See also Section 9.11 following.

9.11 Thermostatically controlled or pressure equalising shower valves will guard against the flow of water at too high a temperature.

9.12 The head of a loose head shower must not fall closer than 25mm (1in.) above the top edge of the bath to prevent its immersion in bath water. Alternatively the shower must be fitted with an anti-siphonage device at the point of the flexible hose connections.

9.13 The supply of hot and cold mains water direct to a bidet is permitted, (subject to local Water Company requirements), provided that the bidet is of the over-rim flushing type. The outlet(s) should be shrouded and unable to have any temporary hand held spray attached. No anti-siphonage arrangements are necessary.

9.14 **LIME SCALE.** In temporary hard water areas (more than 350mg/litre or 200ppm calcium bicarbonate) it is recommended that a proprietary scale reducer is fitted in the mains cold water connection to the appliance. Consult the local water company for additional advice.

Installation of a scale inhibitor assembly should be in accordance with the requirements of the local Water Company. An isolating valve should be fitted to allow servicing. The water hardness can be determined by reference to the local Water Company.

9.15 **NOTE: HOT WATER ONLY.**

If required the appliance may be used for Hot Water only before the Central Heating is connected. A 22mm copper bypass pipe at least 4 metres long must be connected between the Central Heating Flow and Return, but it is advisable to connect a small radiator instead.

IT IS NOT RECOMMENDED TO USE THE BOILER IN THIS CONDITION FOR EXTENDED PERIODS.

Fig. 5. 230V room thermostat connections.

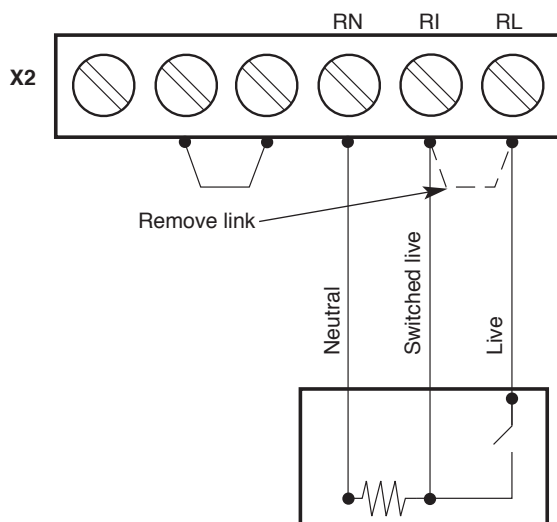
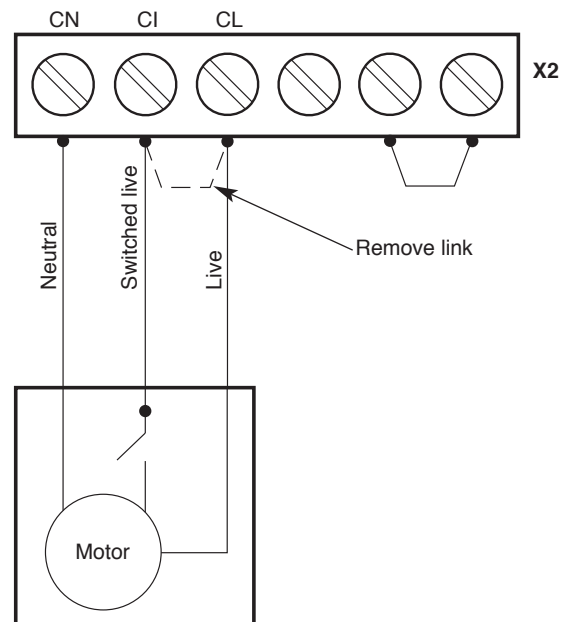

Fig. 6. 230V programmer connections.



10. Electrical

10.1 MAINS SUPPLY.

230 V ~ , 50 Hz, 180 watts.

External Fuse: 3A. Internal Fuses: 2AT HRC(F1), and 1.AF (F2).

10.2 It must be possible to completely isolate the appliance.

10.3 The following connection alternatives must be used:

A 3 amp fused three-pin plug and unswitched shuttered socket outlet (both complying with the requirements of BS 1363) or a double pole isolator with a contact separation of 3mm in all poles and supplying the appliance and controls only.

10.4 The appliance must be earthed.

10.5 Mains Cable. 0.75mm² (24 x 0.20mm) to BS 6500 Table 16. The mains cable must be connected into the terminal X1, marked L (Brown or Red lead), N (Blue or Black lead) and the earth stud and be held securely in the cable clamp. For access undo the three bottom screws and remove the fascia access cover. See Fig. 7.

10.6 The wiring between the appliance and the electrical supply shall comply with current IEE Wiring Regulations and any local regulations which apply.

10.7 If a room thermostat and/or external programmer is to be fitted refer to Figs 5 and 6. The devices must be suitable for use with mains voltage.

10.8 A fascia mounted mechanical programmer is available as an optional extra. Instructions are supplied with the programmer kits.

10.9 A time switch or programmer can be fitted externally to the appliance.

10.10 The boiler provides automatic frost protection, so the use of a frost thermostat is not recommended. However if an external frost thermostat is considered necessary then it must

be used in conjunction with a programmer.

Important: To provide external frost protection the appliance **must** have the Central Heating Temperature Control Knob set to supply heating (the appliance may then be left with the central heating turned off on the programmer).

Connection must be made at X2 terminals RI and CL. For advice on external frost thermostats contact Worcester Heat Systems Technical Helpline

10.11 SAFETY CHECK.

After installation or in the event of an electrical fault the electrical system shall be checked for short circuits, fuse failure, incorrect polarity of connections, earth continuity and resistance to earth.

Fig. 7. Mains electricity connections.

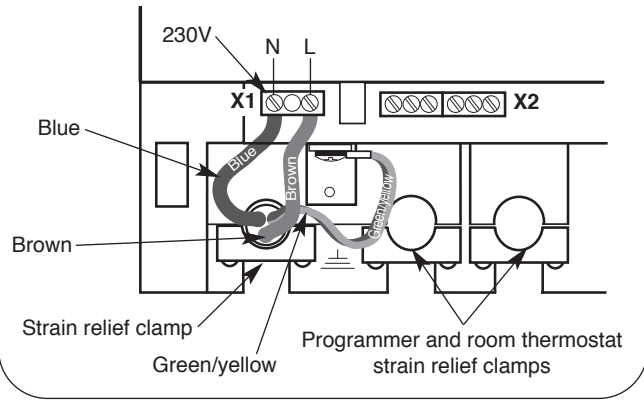

Fig. 8. Wiring diagram.

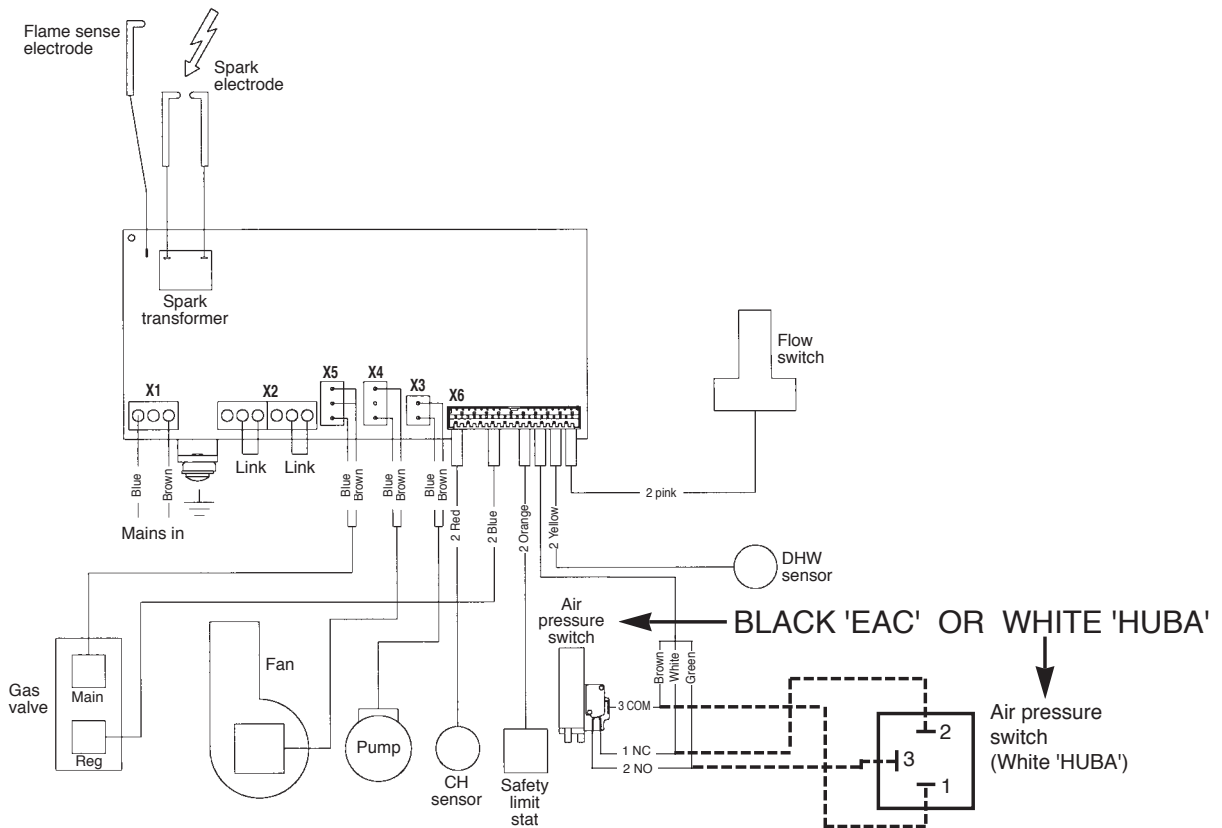
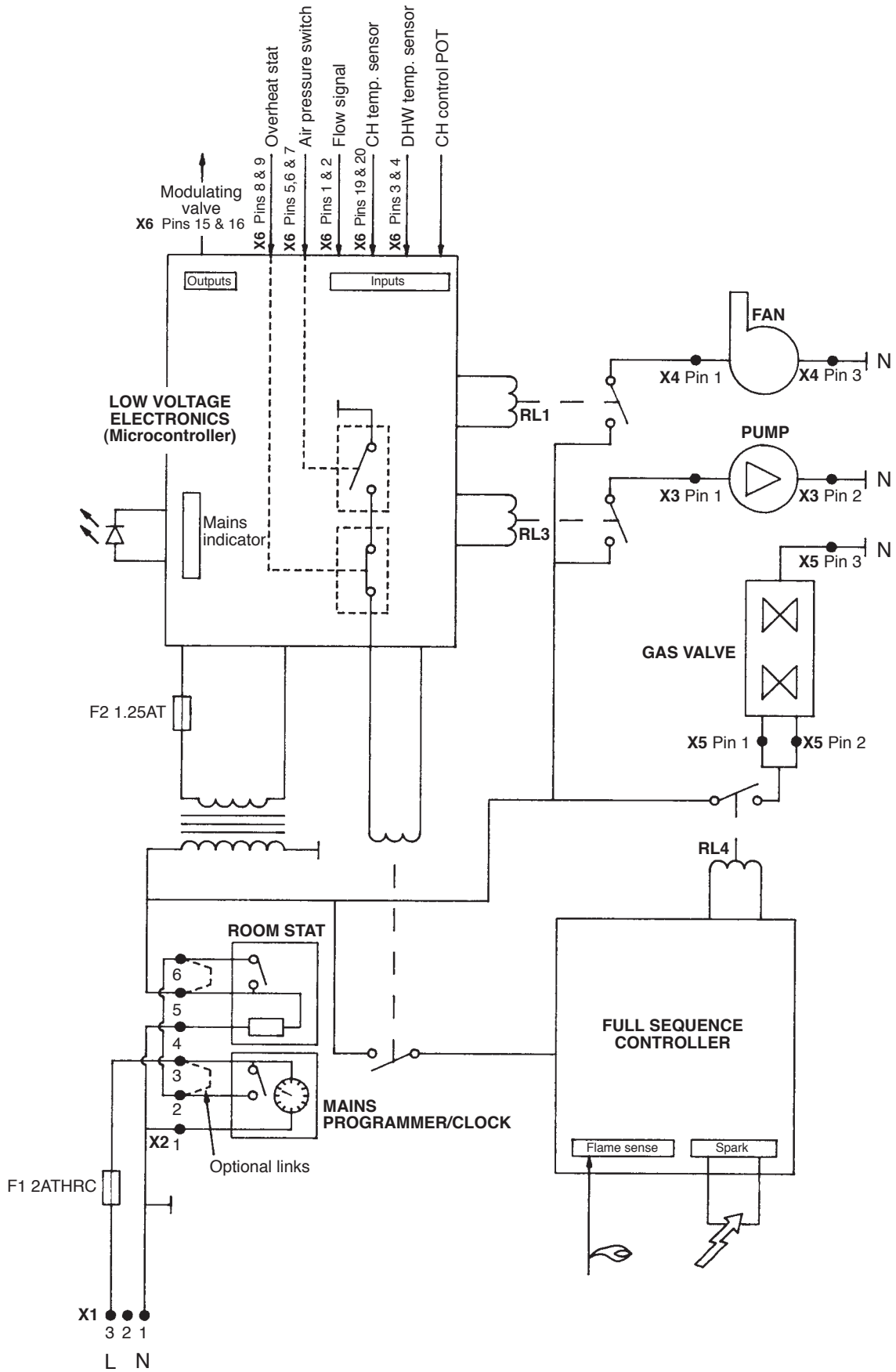

Fig. 9. Functional flow diagram.



11. Installing The Appliance

Note: READ THIS SECTION FULLY BEFORE COMMENCING INSTALLATION.

11.1 General

The appliance is only suitable for fitting to a sealed system.

The flue must be installed as specified in BS5440:1.

Check that the appliance is suitable for the local conditions. i.e. gas supply.

11.2 Unpacking

Remove the appliance from its packaging and check the contents against the packing list.

11.3 Site Preparation

Check the correct position for the appliance has been chosen.

Refer to Sections 4 and 5.

Check that the wall is flat and will support the weight of the appliance.

11.4 Fixing Holes and Flue Opening

Hold the template against the wall.

Check that the template is level.

Mark the position of the fixing holes and the flue opening. Refer to Fig. 10.

Mark the centre-lines of the pipe connections to aid the pre-plumbing of the system pipework.

Check the position of the fixing points and the flue opening before drilling the fixing holes 60mm deep for the No.12 size plugs and cutting the flue duct hole at 110mm diameter (150mm diameter for internally fitted flues).

11.5 Wall Mounting Plate and Manifold

Fit the plugs and fix the top support to the wall. Refer to Fig. 10.

Check the top support is properly aligned before tightening the screws.

11.6 Gas and Water Pipes

Remove the gas cock and fix the appropriate fitting to connect the inlet pipe and re-fit.

Pre-plumbing is not recommended if no movement in the pipes is available.

If it is necessary for the pipes to run up the back of the appliance then they must be arranged to pass behind the expansion vessel.

Pipework must not run horizontally within the limits of the casing.

It is important that the pipes are not fixed near the appliance using clips that put a strain on the connections.

benchmark Before the appliance is fitted to the wall thoroughly flush the system and mains water supply.

Fig. 10. Appliance mounting plate and flue position.

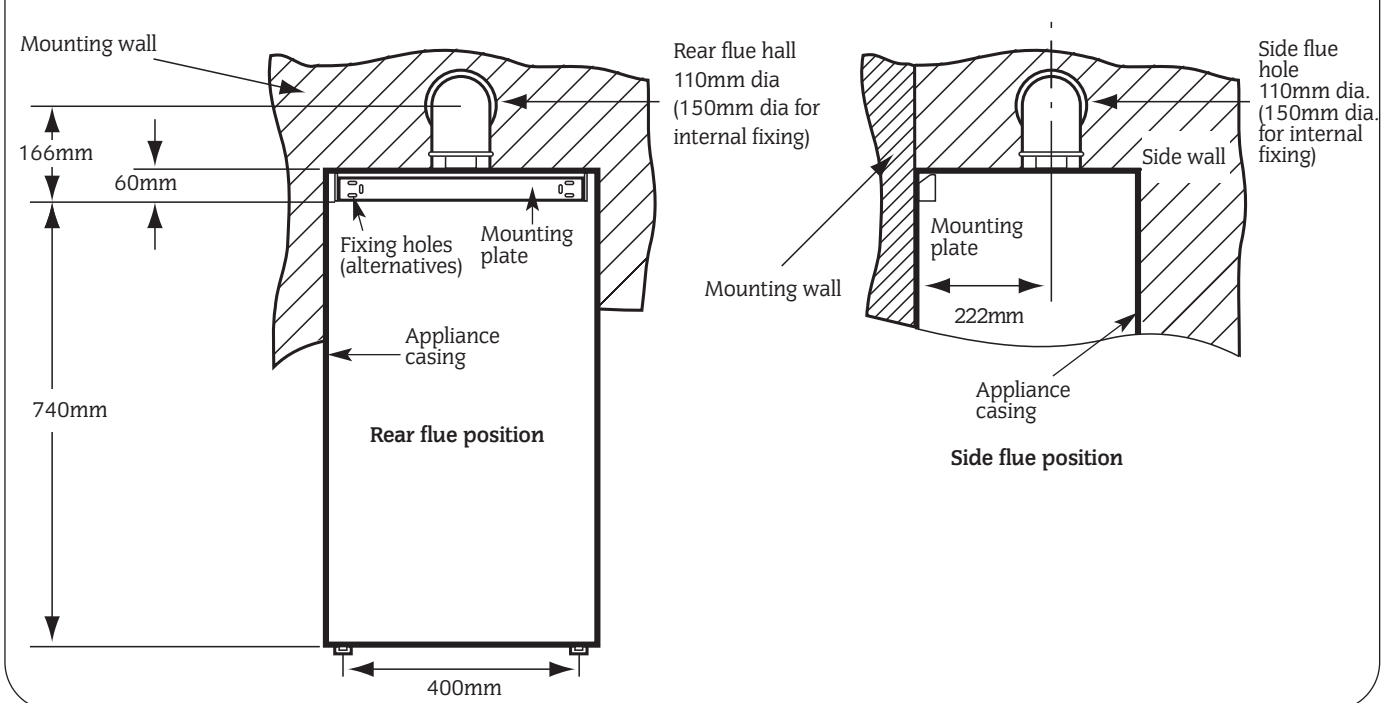
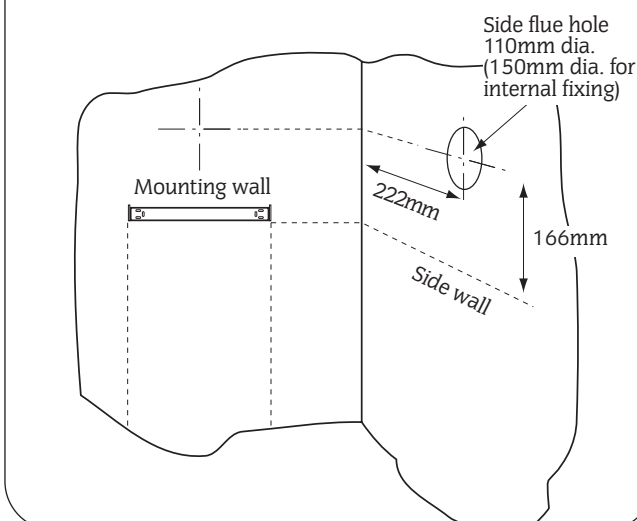

Fig. 11. Marking out the side flue position.



11.7 Install the Boiler

Remove the cabinet by releasing the sides and lifting from the top location.

Check that the gas and water valves are closed.

Lift the appliance to the wall, engage in the top support. Fix and tighten the bottom screws. Refer to Fig. 10.

Tighten the gas and water connections.

Fit a discharge pipe to the relief valve leading it away from any electrics or where it might be a hazard.

The pipe must not be less than 15mm in diameter and must run continuously downward outside the appliance. Refer to Fig. 13.

Fig. 12. Appliance casing and control equipment fixings.

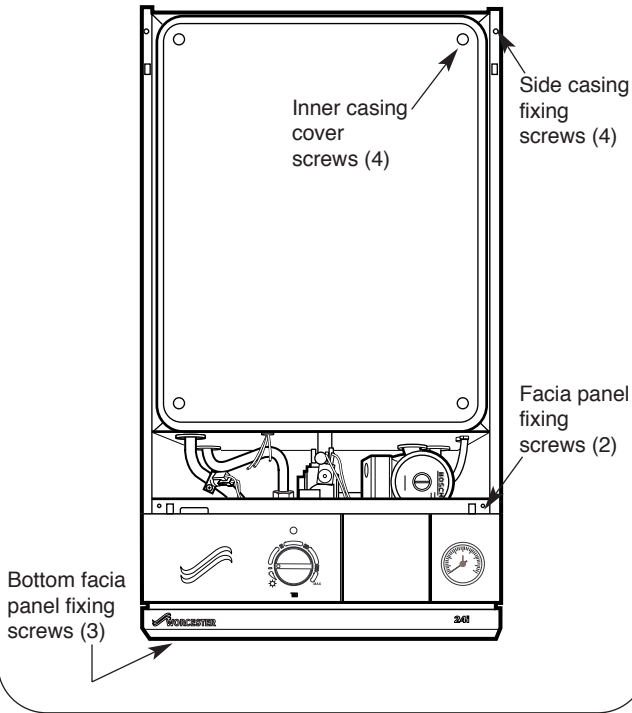

11.8 Air and Flue Duct Preparation

The method of installation of the flue system may be varied to suit the actual site conditions. The instructions for connecting and fixing the ducts must, however, be strictly followed.

Remove all packing material from the flue components.

Fig. 13. Appliance pipework connections.

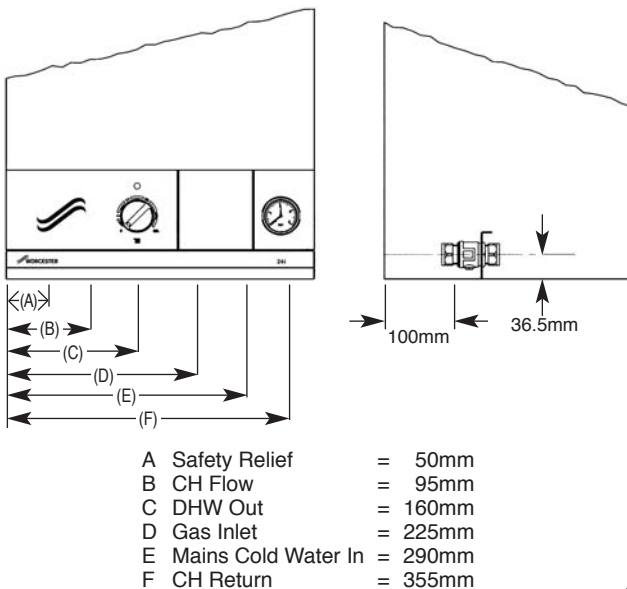

The standard telescopic flue assembly is suitable for flues from 425mm (without cutting) up to 725mm measured from the centre-line of the boiler flue outlet to the outer face of the wall. Refer to Fig. 14.

If L is greater than 725mm then flue extension kits will be required - each kit extends the flue by 750mm up to a maximum of 2500mm. See table below.

EXTENSION	MAXIMUM FLUE LENGTH mm
1	1475
2	2225
3	2500

11.9 Measure and Cut the Ducts

General: Cut the ducts as necessary, ensuring that the ducts are square and free from burrs. Always check the dimensions before cutting.

Measure the distance L. Refer to Fig. 16 and 17 .

The standard flue can be telescopically adjusted to any length between 425mm and 725mm.

Fix the flue assembly together using the self-tapping screw provided. Refer to Fig. 14.

It will only be necessary to cut the standard assembly if L is less than 425mm. Cut the flue turret assembly and the terminal assembly by the same amount i.e L = 350 - remove 75mm from each assembly.

Minimum side flue length = 335mm (accommodating a 10mm Service clearance and a 100mm wall)

Minimum rear flue length = 322mm (accommodating a 100mm wall)

If L is between 1175 - 1475mm (1 extension)
1925 - 2225mm (2 extension)

it is not necessary to cut the ducts.

Fig.14 . Standard flue assembly.

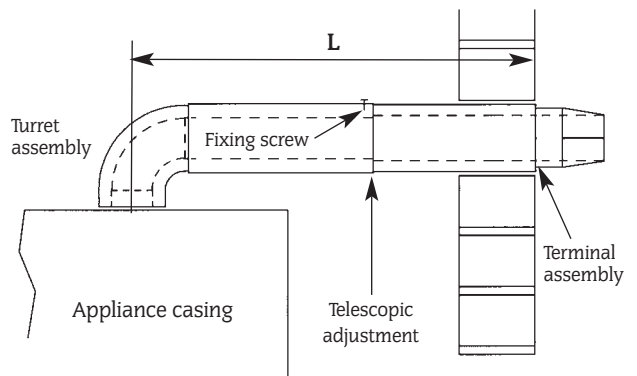

Fig. 15. Extension Duct.

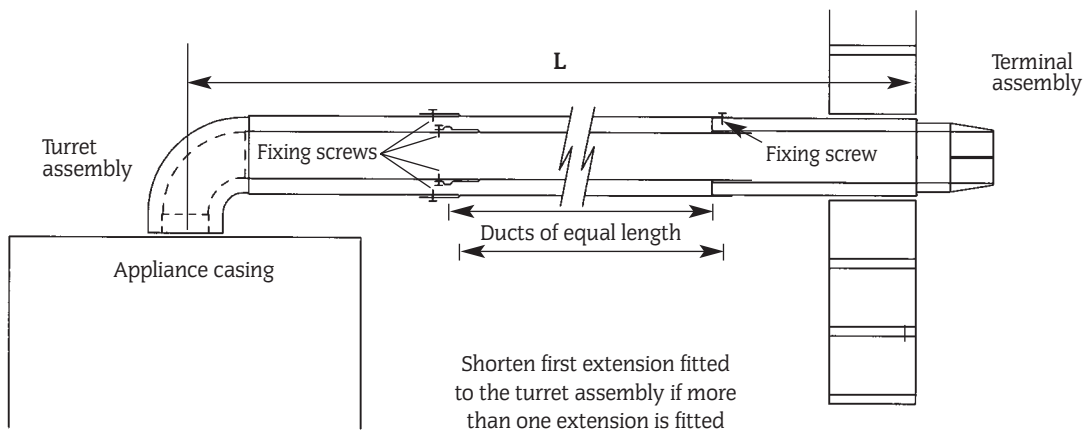
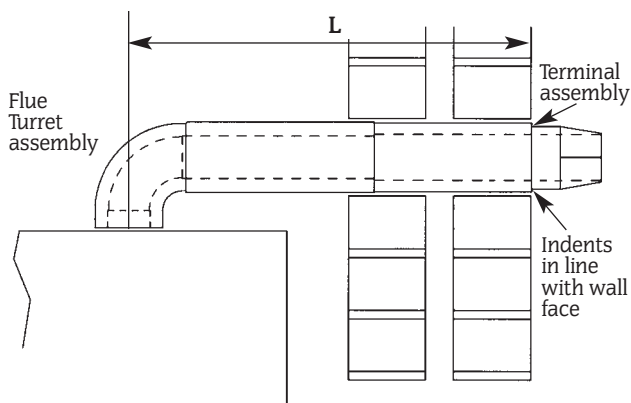

Fig. 16. Flue duct length (side flue).



If L is between:

725 - 1175mm	(1 extension)
1475 - 1925mm	(2 extension)
2225 - 2500mm	(3 extension)

it is necessary to shorten the assembly by cutting the first extension duct assembly i.e. $L = 1000\text{mm}$ - remove 175mm from the air and flue ducts.

NOTE: Extension duct measurements do not include the socketed end. Unless specifically instructed the socketed end must not be removed.

Fix the flue ducts together before fixing the surrounding air duct, the cut ducts fit into the flue assembly.

11.10 Fitting the Flue Assembly with Access to the Terminal

Prepare the flue duct assembly as described in Section 11.9.

Apply the plastic tape to the air duct in contact with the external brickwork.

From inside push the assembly through the wall. Align the flue turret and push fully onto the spigot on the appliance. Tighten the clamping ring and fix with the screw provided. Refer to Fig. 18.

Fig. 17 . Rear flue.

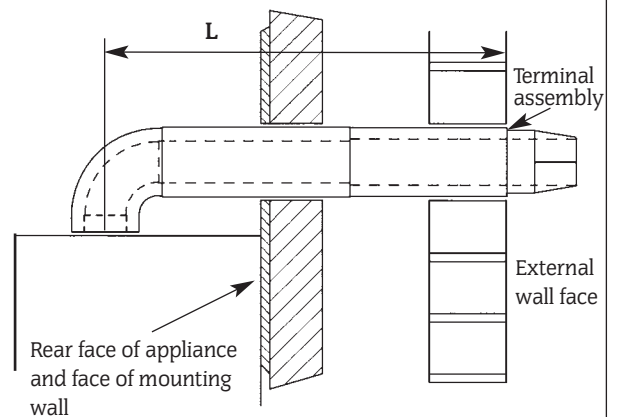

Make good the internal wall face and the external brickwork or rendering.

Replace the inner casing.

11.11 Fitting of the Flue Assembly without access to the Terminal

A rubber gasket kit is available from Worcester Heat Systems. NOTE: A larger diameter opening in the wall is required. Refer to Table 2.

Prepare the flue assembly as described in Section 11.9.

Fit the rubber sealing gasket centrally onto the terminal assembly and tighten the clamp. Refer to Fig. 19.

Apply the plastic tape to the air duct in contact with the external brickwork.

From inside push the assembly through the wall so that the gasket flange is against the outer face. Refer to Fig. 19.

It may be necessary to adjust the legs of the flue centering ring. Align the flue turret and push fully onto the socket on the appliance. Tighten the clamping ring and fix with the screw provided. Refer to Fig. 18.

Seal the gap around the duct at the inner wall face with the flexible seal provided and make good.

Replace the inner casing.

Fig. 18. Flue Turret Fixing .

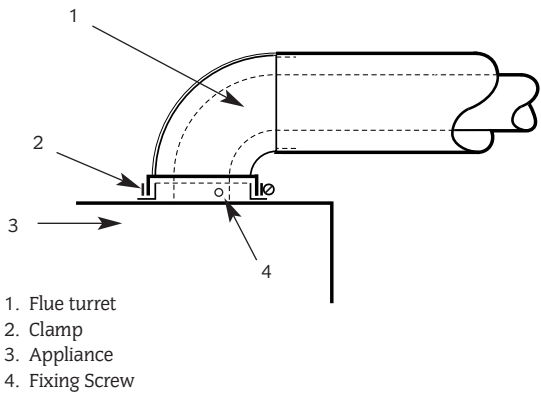

- 1. Flue turret
- 2. Clamp
- 3. Appliance
- 4. Fixing Screw

11.12 Flue Bends

90° and 45° bends are available. A maximum of two bends may be used in addition to the first bend on the flue turret. A 90° bend is equivalent to 750mm of straight duct. A 45° bend is equivalent to 375mm of straight duct.

Fig. 19. Terminal assembly for internal fitting of the flue.

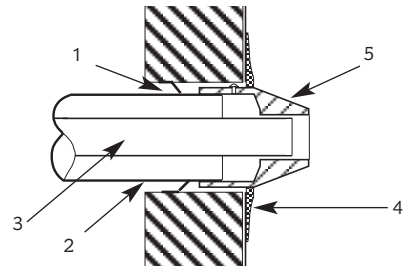

- 1. Flue centering ring
- 2. Air duct
- 3. Flue duct
- 4. Rubber sealing gasket
- 5. Flue Terminal

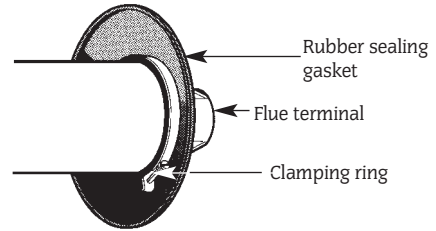
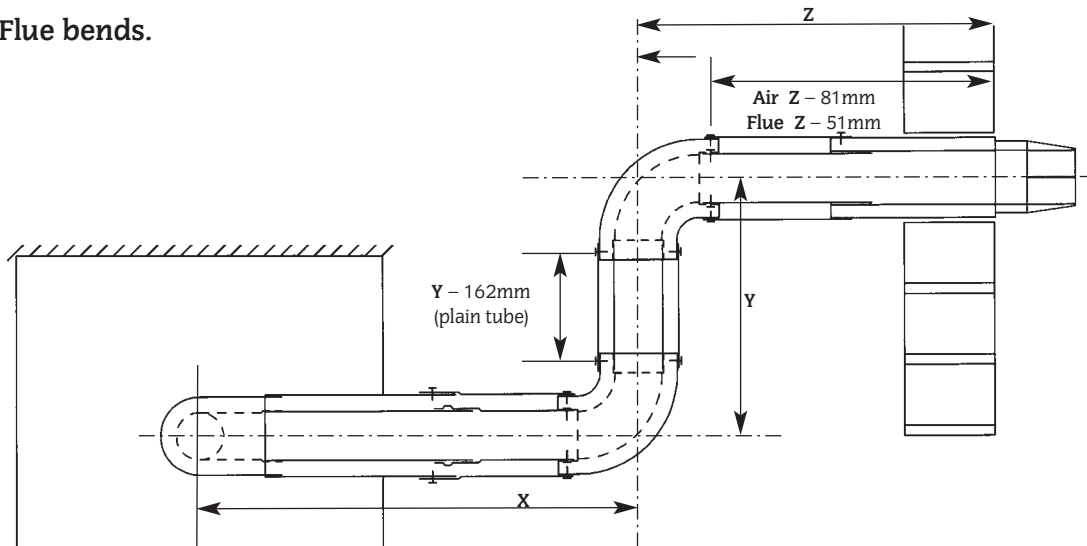

Fig. 20. Flue bends.



A maximum flue assembly of 2.5m is possible with 1 X 90° bend and 2m with 2 X 90° bends.

Measure the lengths X,Y and Z. Refer to Fig. 20.

The maximum value of X using the turret assembly only is 506mm. Reduce the ducts to the appropriate length i.e. X = 406mm, cut 100mm from the air duct and 120mm (to cover the entry into the 45° or 90° elbow) from the flue duct. Refer to Fig.21.

NOTE: The flue system ducts between the elbows, dimension Y, requires the socketed ends (of the first extension if two or more are used) to be removed and the air and flue tubes to be cut to the same length.

Cut the ducts to a length Y - 162mm. Refer to Fig. 20.

The final section, dimension Z, of the flue system must include a section of plain duct assembly i.e. an extension assembly with the sockets removed. Reduce the final section, including the terminal assembly, by the appropriate amount i.e. Air duct Z - 81mm and the flue duct Z - 51mm. Refer to Fig. 20.

If Z < 425mm it will be necessary to cut the air and flue ducts of the extension to a plain length of 100mm and reduce the length

of the terminal assembly i.e Z = 350mm - remove 75mm from the terminal assembly.

If Z in 425 - 725mm it is not necessary to cut the terminal assembly or use a second extension duct as the length can be set telescopically.

If Z > 725mm then two extension duct assemblies will be required, the first assembly being cut to length as plain tubes.

If more than two extension ducts are needed in any section to achieve the required length then the final section of the assembly must not be less than 325mm without cutting the terminal assembly.

NOTE: The flue duct of the final extension must be 30mm longer than the air duct.

Each section must be connected to the previous section of the flue bend by fixing the flue ducts together and then similarly fixing the air ducts which engage the elbows.

Fit the assembly as described in Section 11.10, 11.11 as appropriate.

Make good the internal and external brickwork or rendering.

Fig. 21 - Elbow to Flue Turret Assembly.

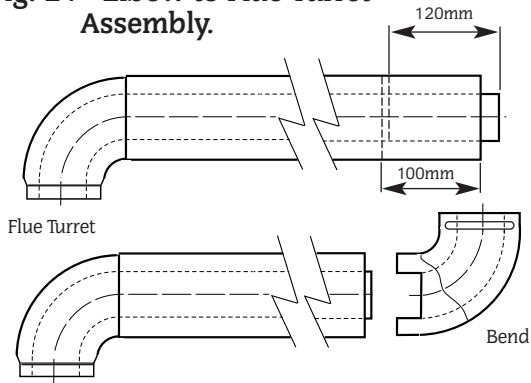
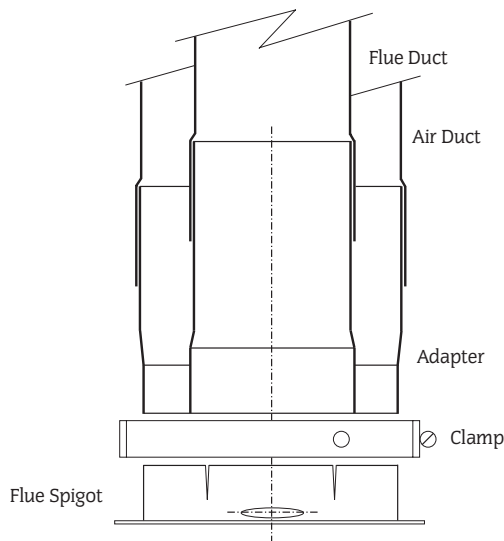

Fig. 22 Vertical Adapter.



11.13 Vertical Adapter for Horizontal Flues

An adapter is available for an initial short section of vertical flue. Refer to Fig. 22.

Measure and cut the flue as described in Section 11.12.

The first, vertical, section (equivalent to dimension X) is measured from the top of the boiler casing. Cut the vertical section of the extension duct to 167mm less than the measured distance. Do not remove the socketed ends.

The minimum measured distance is 167mm.

Seal the air duct to the turret using silicone sealant.

Fix the adapter with the clamp and screw provided.

Fig. 23 - Facia Connections Cover.

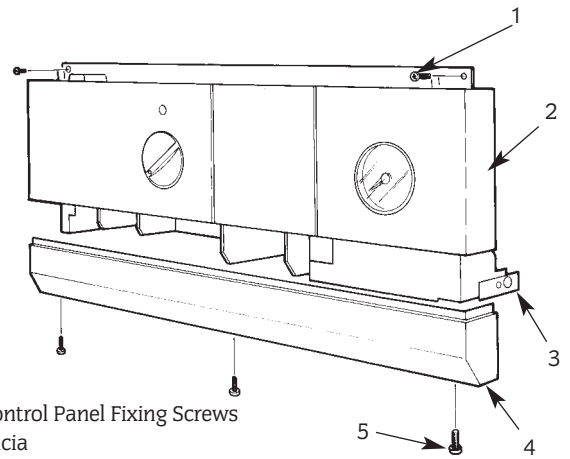

1. Control Panel Fixing Screws
2. Facia
3. Control Panel Pivot Point
4. Connection Cover
5. Connection Cover Fixing Screws

11.14 Completion of the Installation

Check that all the connections on the appliance have been tightened.

Remove the facia bottom panel. Refer to Fig. 23.

Connect the mains electricity supply lead to the appliance and secure the cable clamp. Refer to Fig. 23. and 24.

Check there is sufficient loose lead to allow the release of the facia panel assembly and that the earth lead of the mains supply cable is longer than the live and neutral leads.

Fit the facia mounted clock. Full instructions are sent with the programmer.

Connect any external controls ensuring that the leads pass through the appropriate clamps. Refer to Fig.25.

Test for gas soundness as described in BS6891.

If the appliance is not to be commissioned immediately, replace the cabinet and facia bottom panel. Check that the gas and electricity services have been turned off.

If the premises are to be left unoccupied during frosty conditions then drain the appliance and system. For short inoperative periods, leave the appliance under the control of the built-in frost thermostat or the remote frost thermostat (if fitted) or leave operation continuously with the room thermostat set at 6°C.

Fig. 24 -

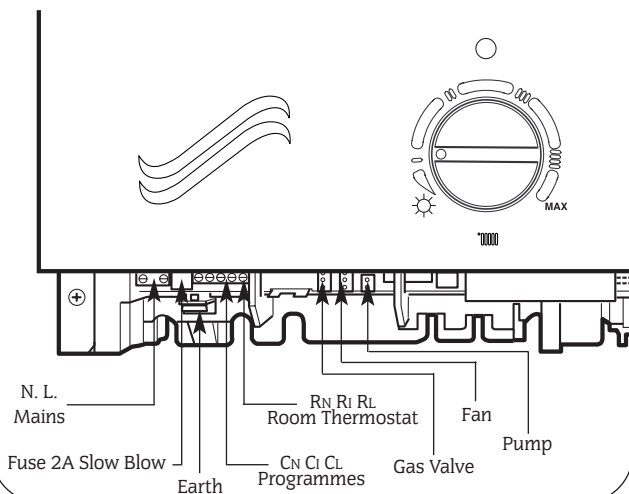
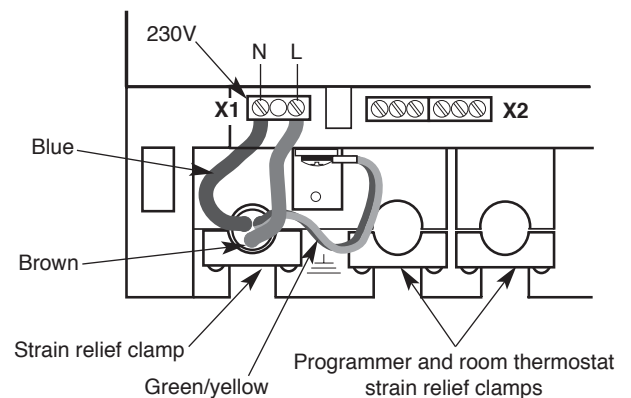

Fig. 25. Mains electricity connections.



12. Commissioning The Appliance



Benchmark Water Treatment: For optimum performance after installation, this boiler and its associated central heating system should be flushed in accordance with the guidelines given in BS7593:1992 - Treatment of water in domestic hot water systems. Full instructions are supplied with proprietary cleansers sold for this purpose. If an inhibitor is to be used after flushing, it should be used in accordance with the inhibitor manufacturers instructions.

Suitable flushing agents and inhibitors are available from Betz Dearborn Tel: 0151 4209563 and Fernox Tel: 01799 550811. Instructions for use are supplied with these products.

12.1 SUMMARY

The appliance is dispatched with the controls set to provide a maximum output for domestic hot water and central heating of 23.4 kW (80,000 Btu/h). The appliance automatically modulates to satisfy lower heat loads.

Domestic Hot Water and Central Heating Systems. Check that both the mains water supply and central heating systems have been fully flushed out at installation.

Fig. 26. Appliance casing and control equipment fixings.

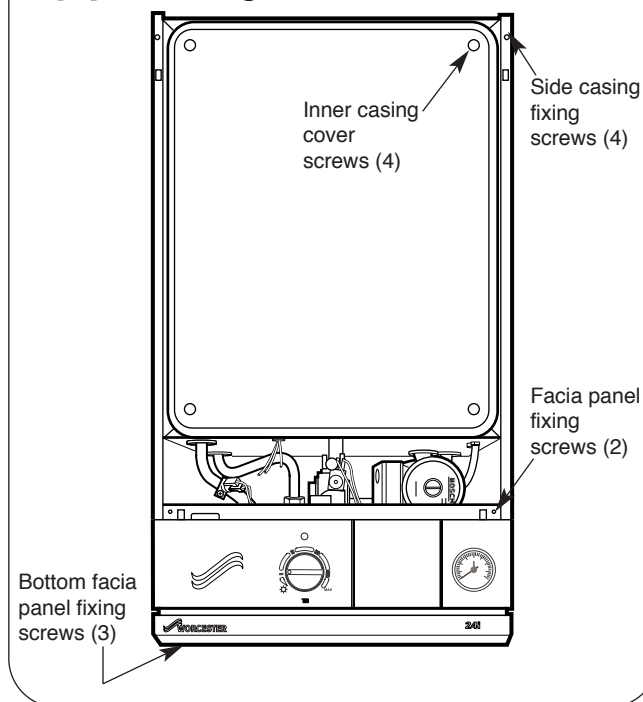

Gas Service. The complete system, including the meter, must be inspected and tested for soundness and purged as indicated in BS 6891.

12.2 APPLIANCE AND CENTRAL HEATING SYSTEM PREPARATION

Remove the cabinet front panel.

Check that the electrical supply and the gas service to the appliance are off.

Check that all the water connections throughout the system are tight.

Open the system valves at the appliance. Open all the radiator valves, fill the system and vent each radiator in turn.

Remove the inner casing cover as described in section 14.3(b). See Fig 26.

The automatic air vent will vent the appliance. Check that the air vent cap has been removed. See Fig. 27.

Check that the pressure relief valve operates by turning the knob anti-clockwise until it releases. Water should be expelled from the discharge pipe. See Fig. 28. Lower the control box to gain

Fig. 27. Appliance components and fixings (upper assembly).

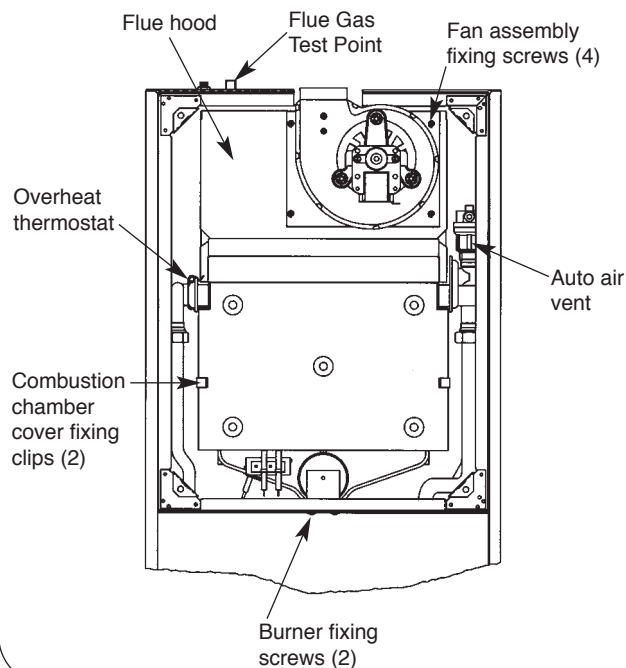

access. Refer to Section 14.3(c).

Set the Expansion Vessel Pressure

The charge pressure of the expansion vessel as dispatched is 0.5 bar, which is equivalent to a static head of 5 metres (17ft). The charge pressure must not be less than the static head at the point of connection. A Schraeder type tyre valve is fitted to the expansion vessel to allow the charge pressure to be increased if necessary.

Set the System Pressure

Fill the system until the pressure gauge shows 2.5 bar (37 lb/ins²) and check for water soundness. Release water from the system using the relief valve test knob until the initial System Design Pressure is obtained, up to a maximum of 1.5 bar.

Initial System Design Pressure (bar) = Expansion Vessel Charge Pressure + 0.3 (bar).

Note: 1 bar is equivalent to 10.2 metres (33.5 ft) of water.

Set the movable pointer on the pressure gauge to coincide with the indicating pointer giving a permanent record of the set system pressure.

Fig. 28. Pressure relief valve.

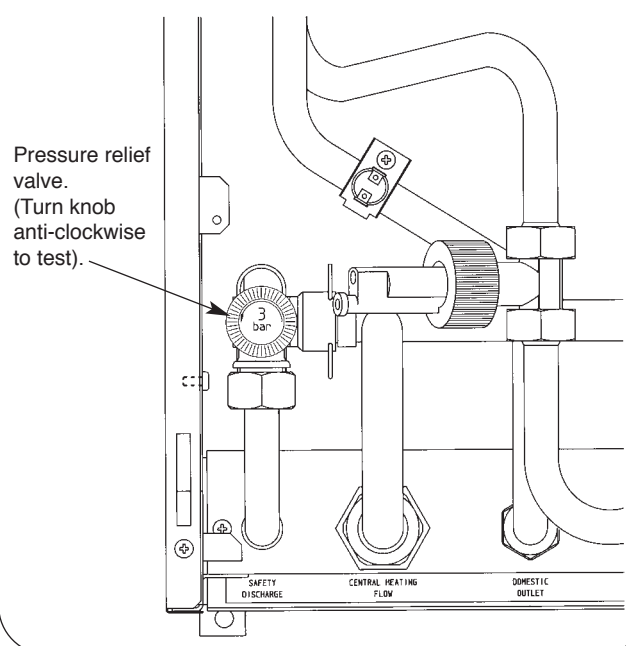

If the pressure indicated on the pressure gauge is greater than 2.6 bar when operating at the maximum central heating temperature, an extra expansion vessel must be fitted to the system as close as possible to the appliance central heating return connection.

The appliance (as dispatched) can accommodate a system volume of about 100 litres. Refer to BS 7074 Part 1. If the system volume is in excess of that accommodated by the expansion

Fig. 29. Gas valve.

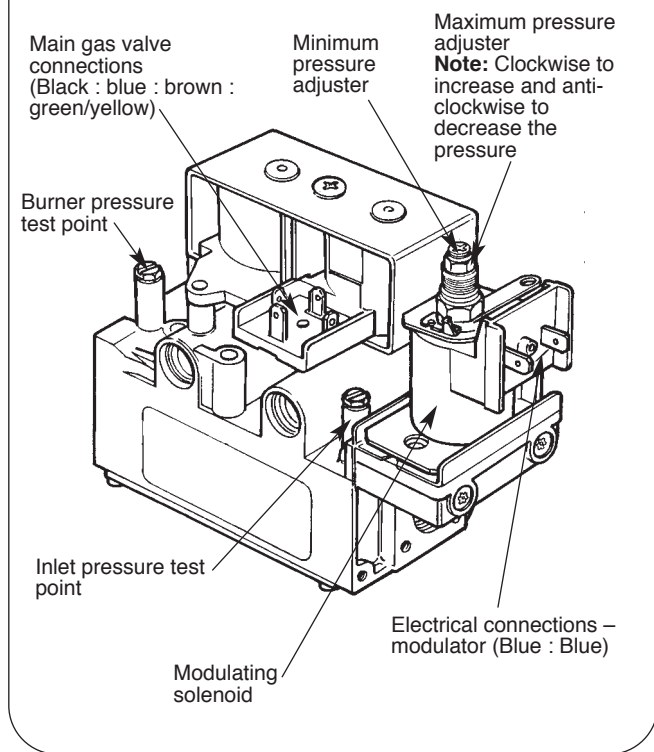

vessel fitted to the appliance then an extra vessel must be fitted as close as possible to the central heating return connection of the appliance.

Any extra vessel fitted must be pressurised to the same figure as the integral vessel. If the expansion vessel fails then the specified replacement must be fitted.

12.3 PROGRAMMER

Any programmer fitted on the appliance should be set up at this stage following the instructions sent with the programmer.

12.4 APPLIANCE OPERATION

Turn off the gas and electricity supplies to the appliance.

Undo the two screws and hinge down the fascia.

Loosen the burner pressure test point screw and connect a pressure gauge. See Fig. 29.

Domestic Hot Water.

Set any Programmer to HEATING & WATER.

Turn on the gas and electricity supplies.

Set the Central Heating temperature control knob to Off.

A tap should be opened to create a hot water demand then a continuous ignition spark will occur until the burner is alight and sensed by the control circuit. The burner will light and remain at its maximum setting. The burner pressure should be between 13.4 and 13.8 mbar on Natural gas (33.0 and 35.0 mbar on Propane). If the burner pressure is low, check that the supply pressure at the gas valve inlet is at least 19 mbar for Natural gas (37 mbar for Propane).

Test for gas soundness at the joint between the burner and the gas valve with leak detection fluid.

Note: The burner pressure is factory set and if (after checking that the supply pressure is sufficient) the correct pressure is not obtained then Worcester Heat Systems Service Department should be contacted.

Gradually close the hot tap and check that the burner pressure drops. Fully open the tap and check that the burner pressure

rises. Fully close the tap and check that the burner goes off. The fan may continue running until the appliance has cooled.

Central Heating

Check that all the radiator valves are open.

Check that the system is pressurised and set to the required pressure as indicated on the gauge.

Set any Programmer to HEATING & WATER.

Turn on the gas and electricity supplies.

Set the room thermostat and the Central Heating Temperature Control to maximum.

The burner will light.

The appliance will modulate its output between 7.5 and 23.4 kW over a period of about twenty minutes.

Check the system to ensure that all the radiators are heating up evenly.

Shut down all but one of the radiators and observe the burner pressure fall. Open all of the radiator valves and check that the burner pressure rises.

Balance the system so that the required temperature difference across the central heating flow and return pipes is obtained. See Table 3, Section 3 Data Tables.

Set the room thermostat to minimum and check that the burner goes out. Reset the room thermostat to maximum and the burner will re-light after a short anti-cycle delay and follow the normal operating procedure.

Check for proper ignition of the burner after a break in the gas supply. Turn off the gas service cock and wait for 60 seconds. The burner will go out but sparking from the electrode will continue for 10 seconds when the appliance will enter a "lockout" state. Carefully open the gas service cock, interrupt the mains power supply to the appliance for a few seconds to reset the controls and observe the burner re-light and follow the normal sequence of operation.

Turn off the gas service cock and the electrical supply to the appliance.

Drain the system while the appliance is still hot.

Refill, vent and re-pressurise as described in Section 12.2.

Domestic Hot Water and Central Heating

Turn on the electricity supply to the appliance and open the gas supply cock at the appliance.

Set the Central Heating temperature control knob to demand and any programmer to HEATING & WATER. If a programmer is fitted, set the domestic hot water to Continuous or 24 Hrs and the central heating to ON. The burner will light and heat will pass into the system. Turn on a hot water tap and check that after a short delay fully heated hot water is discharged from the tap.

Close the tap and the burner will go off. After a short time the appliance will then return to the central heating mode and automatically balance with the system requirements.

Set the Central Heating Temperature Control Knob to OFF and the burner will go out.

12.5 COMPLETION OF COMMISSIONING

Disconnect the pressure gauge and tighten the test point screw.

Restart the appliance and check for gas soundness around the test point screw.

Refit the cabinet front panel.

If the appliance is being passed over to the user immediately, refer to Section 13 - Instructions to the User and set the controls to the users requirements.

If the appliance is to be left inoperative, check that the Central Heating Temperature Control is set to OFF. Turn off the gas service cock and switch off the electricity supply.

If there is any possibility of the appliance and system being left inoperative during frosty conditions, drain the appliance and system. If the premises are to be left unoccupied during frosty conditions, then drain the appliance and system. For short inoperative periods, leave the appliance under the control of the built in frost thermostat or the remote frost thermostat (if fitted) or leave operating continuously with the room thermostat set at 6°C.

13. Instructions To The User

benchmark

- 13.1 Tell the user how to operate the appliance and hand over the Users Instructions leaflet.
 13.2 Tell the user what to do if the heating system is not to be used in frosty weather.
 13.3 Tell the user the sealed system set pressure.
 13.4 Tell the user of the importance of regular servicing. Worcester Heat Systems Ltd. offer a comprehensive maintenance contract.
 13.5 Set the system controls to the user's requirements.
 13.6 If an external programmer has been fitted which has a programmable domestic hot water facility then it is suggested that this be set to Continuous or the equivalent.
 13.7 Complete and hand over to the user the **Benchmark Log-Book**.

Fig. 30. User controls.

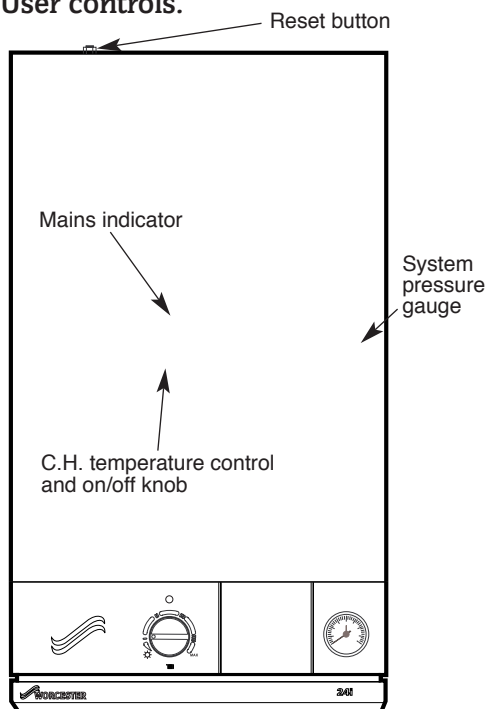

14. Inspection And Service

benchmark

14.1 SERVICING

To ensure continued efficient operation of the appliance it must be checked and serviced as necessary at regular intervals. The frequency of servicing will depend upon the particular installation conditions and usage, but once per year should generally be adequate. The extent of the service required by the appliance is determined by the operating condition of the appliance when tested by fully qualified engineers.

Any service work must be carried out by competent engineers such as British Gas or Corgi registered personnel.

14.2 PRE-SERVICE INSPECTION

Check that the flue terminal and the terminal guard, (if fitted), are clear.

If the appliance is in a compartment, check that the ventilation openings in the compartment door or walls are clear. See Section 6 - Air Supply.

Check the system and remake any joints or fittings which show signs of leakage.

Refill, vent and re-pressurise as described in Section 12.2.

Operate the appliance and the system taking note of any faults.

Measurement of the Flue Gases

For consistency of results of the flue gas measurements it is necessary to have a constant output and for the appliance to be at equilibrium.

Turn on a tap to create a hot water demand.

Wait until the appliance reaches thermal equilibrium (approx. 10 minutes).

Remove the test point sealing screw on the appliance top panel. See Fig. 32.

Connect to the test point with a piece of tubing.

Expected measurements should be between:

Equivalent flue length (metres)	Carbon Dioxide (%)	Carbon Monoxide (%)
0.5	6.9	0.0008
1.0	7.0	0.0009
1.5	7.1	0.0010
2.0	7.3	0.0012
2.5	7.4	0.0013

For Natural Gas:

Equivalent flue length (metres)	Carbon Dioxide (%)	Carbon Monoxide (%)
0.5	7.9	0.0017
1.0	8.0	0.0020
1.5	8.2	0.0024
2.0	8.5	0.0030
2.5	8.8	0.0035

For Propane:

When calculating the equivalent flue length a flue bend is equivalent to 750mm of straight flue.

After taking the measurement replace and tighten the sealing screw.

IMPORTANT

Disconnect the electrical supply at the mains and turn off the gas supply at the gas service cock on the appliance before servicing.

After completing the service always test for gas soundness as indicated in BS 6891.

14.3 DISMANTLE THE APPLIANCE

To carry out a full and comprehensive service of the appliance remove the following parts to gain access to the components which need to be checked or serviced.

Fig. 31. Appliance casing and control equipment fixings.

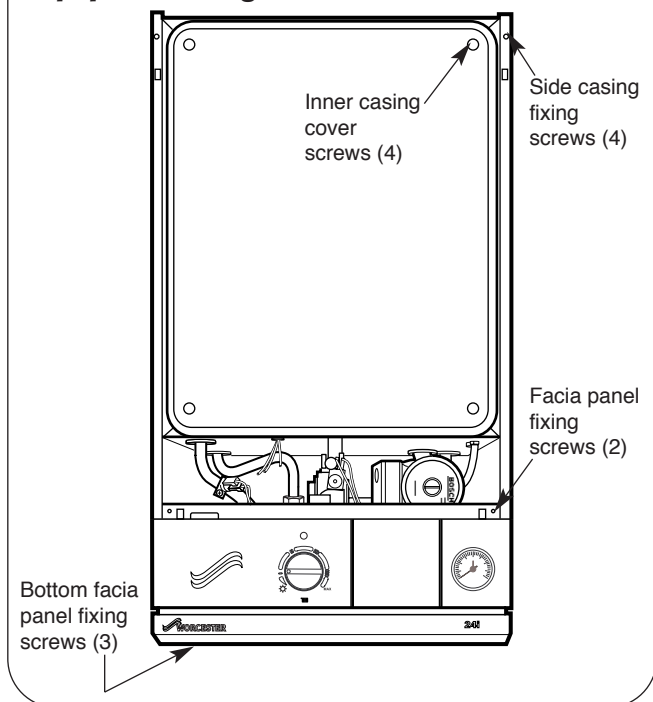

- (a) **Cabinet Front Panel.** Remove by lifting off the supports.
- (b) **Inner Casing Cover.** Check that the electricity supply to the appliance is turned off. Remove the cabinet front panel. Unscrew the four screws securing the cover to the casing and lift off. See Fig. 31.
- (c) **Facia Panel.** Check that the electricity supply to the appliance is turned off. Remove the cabinet front panel. Unscrew the two upper screws as shown in Fig. 31. and hinge down the facia taking care not to damage the pressure gauge capillary tube or electrical connections.

Fig. 32. Appliance components and fixings (upper assembly).

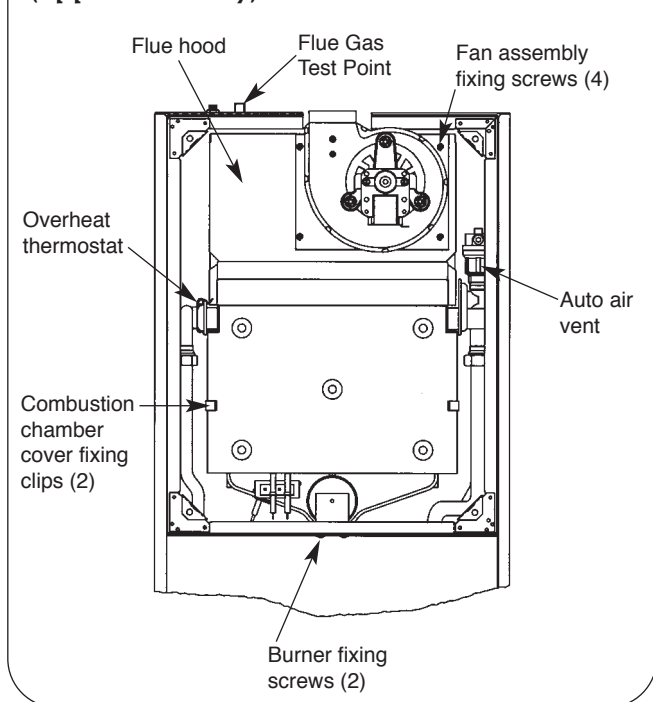

- (d) **Bottom panel.** Unclip and remove the appliance bottom panel.
- (e) **Fan.** Remove the inner casing cover. Carefully unplug the electrical connections and pull off the sensing tubes. Unscrew the four fixing screws and remove the fan assembly. See Fig. 32.
- (f) **Combustion Chamber Front.** Remove the inner casing cover. Undo the spring clips fixing the combustion chamber front. See Fig. 32.
- (g) **Flue Hood Assembly.** Remove the fan assembly. Remove the combustion chamber front. Lift and slide the flue hood assembly from the appliance. See Fig. 32. When refitting the hood ensure that the rear return edge passes under the lip at the rear of the combustion chamber.
- (h) **Burner Assembly.** Remove the combustion chamber front. Pull off the two spark electrode leads and disconnect the flame sense lead. Undo the burner fixing screws. Lift up and remove the burner assembly from the appliance. See Fig. 33.

Fig. 33. Burner and electrode assembly.

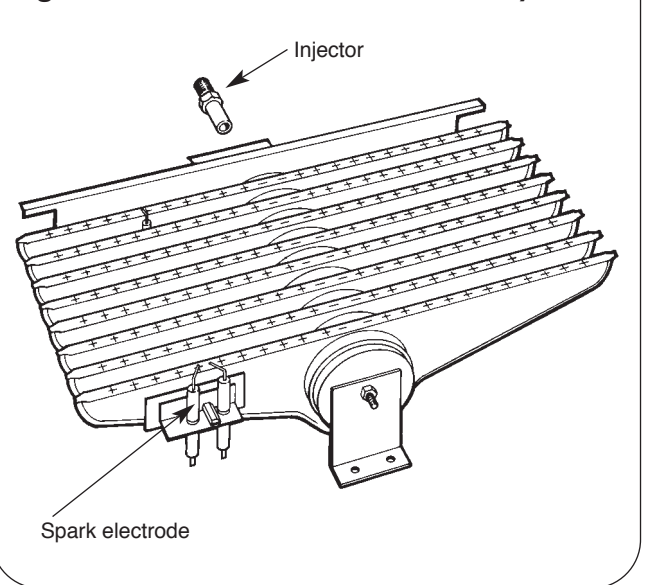

14.4 SERVICE OF COMPONENTS

Clean the Fan. Any dust or fluff should be removed with a soft brush or by blowing. Take care not to distort the pressure sensing device.

Clean the Main Burner. Brush the blade tops and mixing tube with a soft brush and check that all the flame ports are clear. Remove any blockages with a non-metallic brush. Inspect the injector and clean with a soft brush. Replace the injector if it appears damaged. Do not use a wire brush or anything likely to cause damage. Replace the spark and sense electrodes if they appear damaged.

Clean the Gas to Water Heat Exchanger. Clean the heat exchanger using a soft brush. Remove the deposits from the bottom of the combustion chamber. Do not distort any of the blades.

Combustion Chamber Insulation. Examine and replace any pads that are damaged. Remove any dust or deposits using a soft brush.

Reassemble the appliance in the reverse order.

Check that all components are in place and correctly fixed. Leave the cabinet front panel to be fitted after checking the operation of the appliance.

14.5 TEST THE APPLIANCE

On completion of the service and reassembly of the appliance, check for gas soundness and the correct operation of the appliance as described in Section 12 - Commissioning.

Refit the cabinet front panel and reset the controls to the users requirements.

15. Replacement Of Parts

15.1 IMPORTANT

Switch off the electricity and gas supplies before replacing any components. After the replacement of any components, check for gas soundness where relevant and carry out functional checks as described in Section 12 - Commissioning

15.2 COMPONENT ACCESS

To replace components it is necessary to remove one or more sections of the cabinet and cover plates within the appliance as described in Section 14.3. The fascia panel may also need to be hinged down as described in Section 14.3 (c).

15.3 DRAINING THE APPLIANCE

Check that the electricity supply to the appliance is turned off. Before removing any component holding water it is important that as much water as possible is removed from the appliance.

(a) Central Heating Circuit. Turn off the central heating flow and return valves at the appliance. Open the pressure relief valve, make sure that the dust cap on the auto air vent is removed. See Fig. 32. Close the pressure relief valve when the flow has stopped. Some water will remain in the expansion vessel, pump and Gas to Water heat exchangers and extra care must be taken when removing these components.

(b) Domestic Hot Water Circuit. Turn off the mains cold supply valve at the appliance and open the lowest hot water tap. A quantity of water will remain in the Gas to Water heat exchanger, extra care must be taken when removing this component.

15.4 COMPONENT REPLACEMENT

1. Automatic Air Vent. See Figs. 32. and 34.

Remove the inner casing cover as described in Section 14.3 (b). Drain the central heating circuit as described in Section 15.3 (a). Unscrew air vent from the heat exchanger. Fit the replacement assembly ensuring thread sealant is applied and the dust cap is removed. Open the valves and fill and re-pressurise the system as described in Section 12.2.

2. Air Pressure Switch. See Fig. 36.

Check that the electricity supply to the appliance is turned off. Remove the cabinet front panel as described in Section 14.3 (a) and lower the fascia. Section 14.3(c). Carefully pull off the sensing tubes and the electrical connections from the switch. Remember to note their positions. Unscrew the two screws behind the Air Pressure Switch and remove the switch from the appliance.

Fit the replacement switch in the reverse order ensuring that the electrical connections have been made to the correct terminals on the switch. Check that the sensing tubes are fitted correctly.

3. Fan. See Fig. 32.

Check that the electricity supply to the appliance is turned off. Remove the fan assembly as described in Section 14.3(e). Fit the replacement fan in the reverse order.

4. Overheat Thermostat. See Fig. 32 and 34.

Check that the electricity supply to the appliance is turned off. Remove the inner casing cover as described in Section 14.3 (b). Carefully pull off the two wires from the thermostat head. Undo the retaining nut on the top of the appliance and remove the retaining clip from the heat exchanger. Carefully withdraw the thermostat from the appliance.

Fit the replacement thermostat in the reverse order ensuring that some heat sink compound is between the thermostat and the heat exchanger.

5. Gas to Water Heat Exchanger. See Fig. 34.

Check that the electricity supply to the appliance is turned off. Drain the central heating circuit and domestic circuits as described in Section 15.3 (a) and (b).

Remove the inner casing cover, fan, flue hood assembly, combustion chamber front, overheat thermostat, automatic air vent and combustion chamber side insulation as described in Sections 14.3 (b, e, f and g), 15.4 (1) and 15.4 (4).

Fit the replacement heat exchanger in the reverse order ensuring that all the fibre washers are correctly fitted and a layer of heat sink compound is on the thermostat.

Open the valves and fill and re-pressurise the system as described in Section 12.2.

Fig. 34. Combustion chamber.

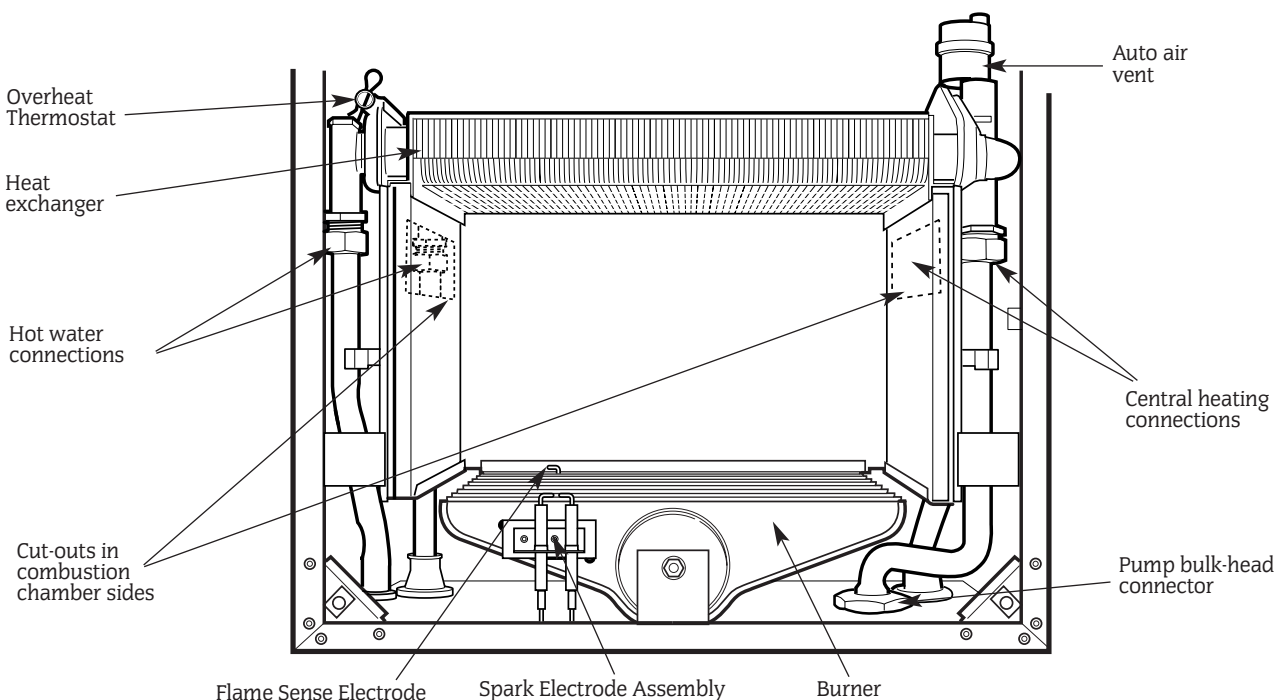

6. Combustion Chamber Insulation.

Check that the electricity supply to the appliance is turned off. Drain the central heating circuit as described in Section 15.3(a). Remove the inner casing cover, fan, flue hood assembly, burner, and Gas to Water heat exchanger as described in Sections 14.3 (b, e and f), and 15.4 (5). Remove the fibre insulation pads from the combustion chamber side, rear, and front sections. Fit the replacement pads in the reverse order taking care not to damage them.

Open the valves and fill and re-pressurise the system as described in Section 12.2.

7. Burner. See Fig. 33.

Check that the electricity and gas supplies to the appliance are turned off.

Remove the burner assembly as described in Section 14.3 (h).

Fit the replacement burner in the reverse order taking care not to damage the electrode leads.

8. Burner Injector. See Fig. 33.

Remove the burner as described in Section 14.3 (h).

Unscrew the brass injector from the manifold.

Fit the replacement injector in the reverse order.

9. Spark Electrode Assembly. See Fig. 33a.

Remove the combustion chamber front as described in 14.3 (g)

Carefully pull off the two electrode leads,

Undo the M4 extended nut and remove the spark electrode assembly from the burner.

Fit the replacement electrode in the reverse order, checking that the spark gap is 3.5 to 4.5mm.

Fig. 33a. Spark electrode assembly.

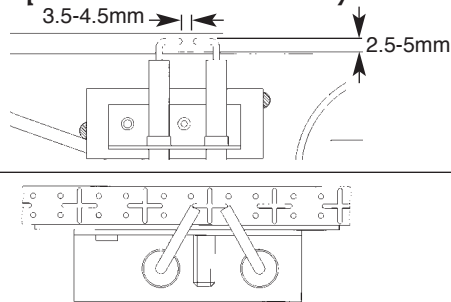

10. Flame Sensor. See Fig. 33.

Remove the burner as described in sections 14.3(h) and 15.4(8). Undo the M3 screw and remove the sense electrode from the burner.

Fit the replacement electrode in the reverse order, checking that the sense gap is 5 to 6mm.

11. Gas Valve. See Figs. 35. and 36.

Check that the electricity and gas supplies to the appliance are turned off.

Hinge down the control box assembly in the servicing position as described in Section 14.3(d).

Whilst supporting the valve unscrew the plug retaining screw and carefully pull off the electrical solenoid plug connection and the two modereg leads.

Undo the 8 manifold screws and remove the gas valve. See Fig. 36.

Fit the replacement gas valve in the reverse order ensuring the "O" rings are correctly fitted.

Turn on the gas supply and check for soundness.

To set the burner pressure. See Fig. 35.

The minimum and maximum burner pressures must be set after a new gas control has been fitted.

The maximum burner pressure must be set first, as any adjustment of the maximum pressure influences the minimum pressure setting.

Start the appliance in the domestic hot water mode as described in section 12.4. - Appliance Operation.

Adjust the maximum pressure adjustment screw on the gas valve to give a burner pressure of 13.6 mbar on natural gas, for propane the maximum pressure adjustment must be increased to maximum clockwise, this should give 33.0 - 35.0 mbar.

End the demand and reset the appliance by interrupting the mains electricity supply. (Otherwise there is a four minute anti-cycle delay at the end of a demand).

Restart the appliance in central heating mode and adjust the minimum adjustment screw on the gas valve to give a pressure of 1.0 mbar on natural gas or 3.5 mbar on propane. See Fig. 35. After completing the adjustments, check the minimum and maximum pressures and re-adjust as necessary. Once this has been done the clear cap should be re-fitted to the adjuster and the retaining screw tightened. Coat the screw with paint or nail varnish to prevent user adjustment.

Fig. 29. Gas valve.

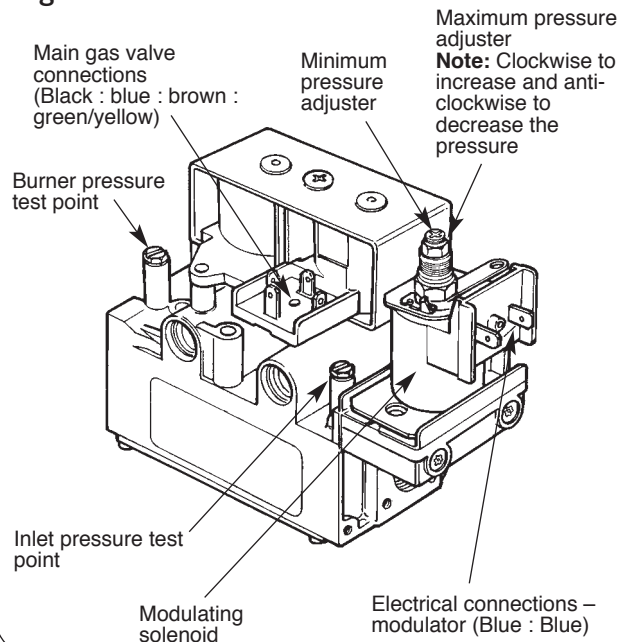

12. Central Heating Sensor. See Fig. 36.

Check that the electricity supply to the appliance is turned off. Hinge the facia assembly in the servicing position as described in Section 14.3(c and d).

Carefully pull off the two leads from the sensor.

Pull off the sensor and spring retaining clip from the pipe.

Fit the replacement sensor in reverse order with a layer of heat

Fig. 36. Gas valve pump and air pressure switch

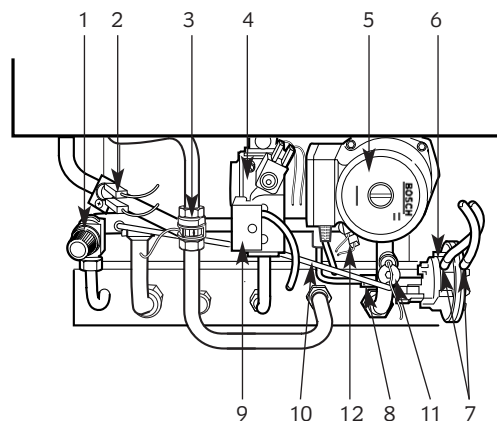

- | | |
|-----------------------------|--|
| 1 Pressure relief valve | 7 Air pressure switch connecting tubes |
| 2 Domestic hot water sensor | 8 Pressure gauge connection |
| 3 Water flow turbine | 9 Gas valve electrical connections |
| 4 Gas valve | 10 By-pass pipe |
| 5 Pump | 11 Fixing disc and screw |
| 6 Air pressure switch | 12 Central heating sensor |

sink compound between the faces. Refit the leads.

13. Domestic Hot Water Sensor.

Check that the electricity supply to the appliance is turned off. Hinge the fascia assembly in the servicing position as described in Section 14.3(c and d).

Carefully pull off the two leads from the sensor.

Undo and remove the clamping screw.

Pull off the sensor and spring retaining clip from the pipe.

Fit the replacement sensor in the reverse order ensuring a layer of heat sink compound is between the faces. Refit the leads.

14. Circulating Pump.

See Figs. 34 and 36. Check that the electricity supply to the appliance is turned off.

Drain the central heating circuit as described in Section 15.3(a).

Hinge the fascia assembly in the servicing position as described in Section 14.3(c).

Undo the two union nuts and the pipe to the expansion vessel, remove the pump from the pipe-work. Support the pump and remove the electrical cover.

Disconnect the electrical wires taking note of their positions.

Fit the replacement pump in the reverse order using new sealing washers.

(Alternatively replace the pump head only by removing the four Allen screws on the pump, remove the head and support whilst removing the electrical connections. Refit the new head).

Open the valves and fill and re-pressurise the system as described in Section 12.2

Note: The direction of flow should be upwards. The speed should always be set to maximum.

15. Expansion Vessel.

Drain the central heating circuit as described in Section 15.3(a).

Isolate the gas supply at the mains.

Then either fit a separate expansion vessel on the central heating return to the appliance or replace the existing vessel as described below.

Drain the domestic circuit as described in Section 15.3(b).

Disconnect the flue system at the boiler.

Disconnect the appliance pipework at the appliance entry points ensuring precautions are taken to cope with any water remaining in the appliance.

Remove the appliance from the wall.

Disconnect the expansion vessel from the appliance by undoing the fitting nut at it's base.

Fit the replacement vessel in the reverse order.

Open the valves and fill and re-pressurise the system as described in Section 12.2

Fig. 37. Pressure relief valve.

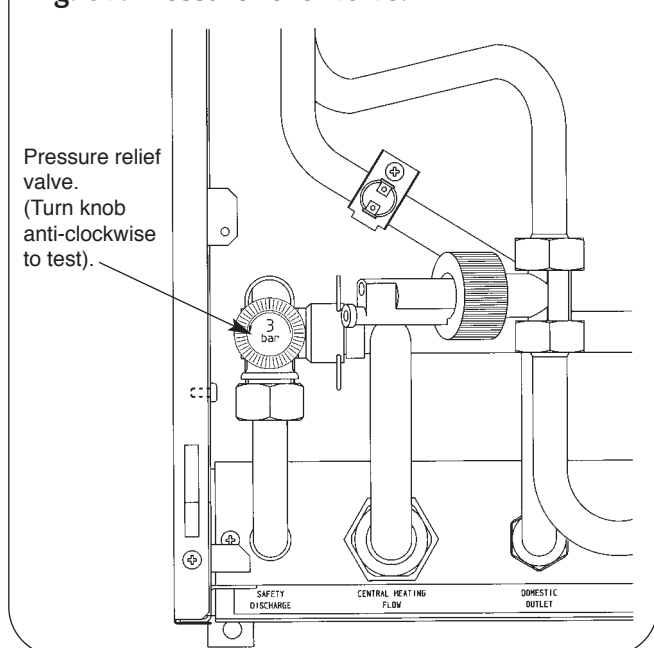

16. Pressure Relief Valve.

See Fig. 37. Drain the central heating circuit as described in Section 15.3(a).

Hinge down the fascia assembly as described in Section 14.3(c)

Remove the Bottom panel as described in Section 14.3(d)

Undo the discharge pipe connection and remove the valve retaining clip. Remove the valve taking care not to distort the pipework.

Fit the replacement valve in reverse order. Reconnect the discharge pipe.

Open the valves and fill and re-pressurise the system as described in Section 12.2

17. Water Flow Switch.

See Fig. 38. Check that the electricity supply to the appliance is turned off.

Drain the domestic hot water circuit as described in Section 15.3(b).

Remove the two upper screws and hinge down the fascia panel as described in Section 14.3(c).

Undo the two union nuts securing the "T" piece and remove the housing from the pipework.

Disconnect the electrical connection.

Fit the replacement water flow switch in the reverse order ensuring new fibre washers are fitted to the new switch body.

Fig. 38. Water Flow Switch. (Side View)

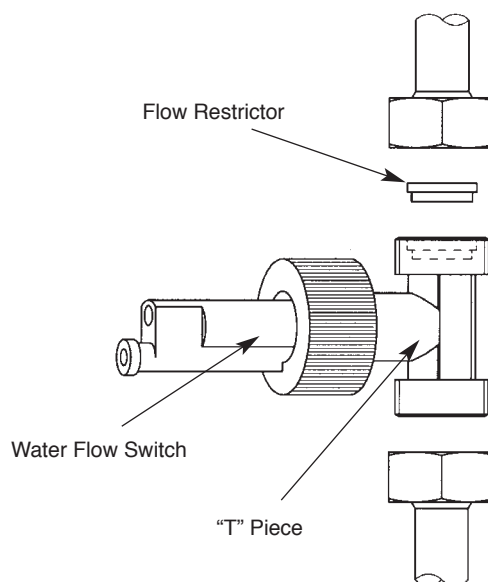

18. Domestic Hot Water Flow Restrictor.

See Fig. 38. Remove the water flow switch as described in Section 15.4-17. Undo the two union nuts securing the "T" piece and remove the housing from the pipework.

The plastic flow restrictor is located within the "T" piece on the water flow switch.

Fit the replacement flow restrictor and reassemble in the reverse order ensuring the fibre washers are in place.

19. Pressure Gauge.

Check that the electricity supply to the appliance is turned off.

Drain the central heating circuit as described in Section 15.3(a).

Remove the two upper screws and hinge down the fascia panel as described in Section 14.3(c).

Prize back the retaining clips securing the gauge to the fascia panel remove wire clip and unplug the gauge from the pump inlet pipe.

Fit the replacement gauge in the reverse order ensuring the "O" ring is in place.

Open the valves and fill and re-pressurise the system as described in Section 12.2

20. Control Board.

Check that the electricity supply to the appliance is turned off. Undo the 3 screws and remove the fascia bottom panel. Remove the two upper screws and hinge down the fascia assembly. Carefully pull off all the connectors. Disconnect the mains supply lead at terminal X1 and the earth connection at the back. Remove the four corner screws on the back of the fascia and separate the metal back panel from the plastic fascia. Remove and retain the brass nut and washer. Release the six pillars on the control board and pull the control board forward off the back panel. Fit the replacement board in the reverse order ensuring it is pushed firmly onto the six pillars and clicks into place. Special care should be taken with the brass post and nut to ensure a good earth contact. (Check earth continuity between the incoming earth and the appliance chassis). Refit the fascia panel and hinge the control box assembly in the servicing position as described in Section 14.3 (c).

21. Gauze filter. See Fig. 39.

Remove the water flow switch as described in section 15.4-17. Undo the lower union nut on flow switch housing. Undo the nut on the isolating valve and remove the mains water inlet pipe. Carefully extract the filter from the valve end of the pipe. Replace the filter and refit the pipe in reverse order using a new fibre washer.

22. Flue flow sensor. See Fig. 40.

Check that the electricity supply to the appliance is turned off. Remove the fan assembly as described in Section 14.3(e). Unscrew the single central retaining screw and withdraw the sensor from the fan.

Fit the new sensor ensuring the correct orientation and carefully tighten the retaining screw. Refit the fan assembly in reverse order.

Fig. 39. Gauze Filter.

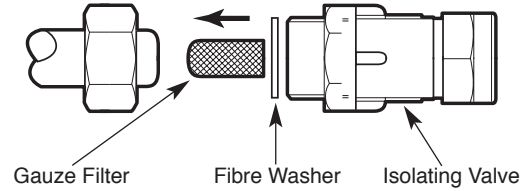
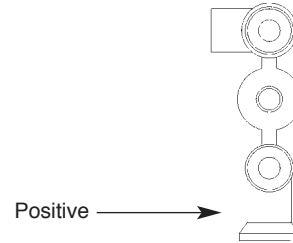

Fig. 40. Flue flow sensor.



16. Conversion Instructions

These instructions should be used when converting appliances from natural gas to LPG and vice versa.

Only components supplied by Worcester Heat Systems should be used.

Only competent persons should attempt the conversion.

Conversion from Natural Gas to LPG should not be carried out on appliances installed in a room or internal space below ground level.

1. Ensure the gas service cock is turned OFF and the electrical supply is isolated.
2. Refer to section 14.3 Dismantle the Appliance to remove the boiler front panel and inner casing. Follow the dismantling instructions to remove the burner.
3. Remove the injector and replace with the injector from the kit.
4. Remove the nut, end cap and bracket from the end of the burner.
 - 4.1 For conversion to Natural gas remove the internal gauze.
 - 4.2 For conversion to LPG fit the gauze into the burner body.

5. Refit the end cap ensuring the bracket is in the correct orientation.
6. Refit the burner to the appliance and re-assemble the inner casing.
7. Follow the dismantling instructions to remove the gas valve and refit the new valve. See Installation Instructions: Section 15.4.11 Replacement of Parts, Component Replacement, Gas Valve.
8. Turn on the gas and electricity supplies and following the commissioning procedure confirm gas soundness and correct boiler operation.
9. Set the gas pressure to the required rate for the new gas type as specified on the data plate. When this is done refit the cap to the adjuster and seal its retaining screw with paint or nail varnish.
10. Turn off the boiler and when cool peel off the arrow from the data plate and re-stick it against the gas type for which the appliance is now converted.
11. Replace the boiler front panel.

The conversion is now complete.

Parts List

Item No.	Description	Natural Gas to LPG Kit	LPG to Natural Gas Kit
		7 716 192 131	7 716 192 132
1.	Burner Injector	8 716 140 209 Stereomatic 2.78mm	8 716 105 033 Stereomatic 4.3mm
2.	Burner Gauze	8 716 142 601	Remove Gauze
3.	Gas Valve	8 716 142 430	8 716 142 413
4.	Copper Washer	8 716 101 994	8 716 101 994

17. Operational Flow Diagrams

1. Central Heating Mode

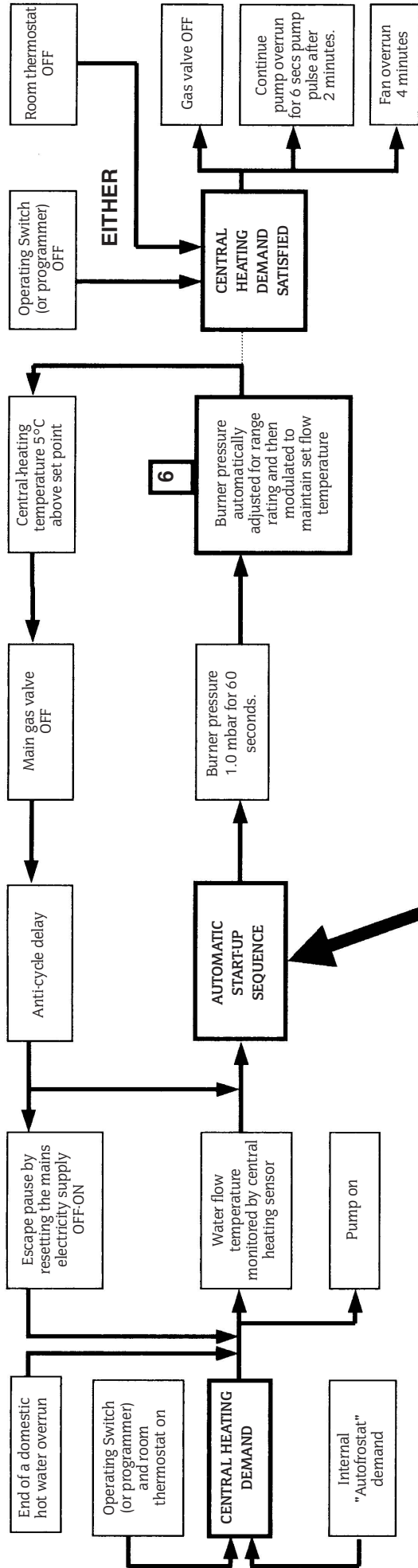

AUTOMATIC START-UP SEQUENCE

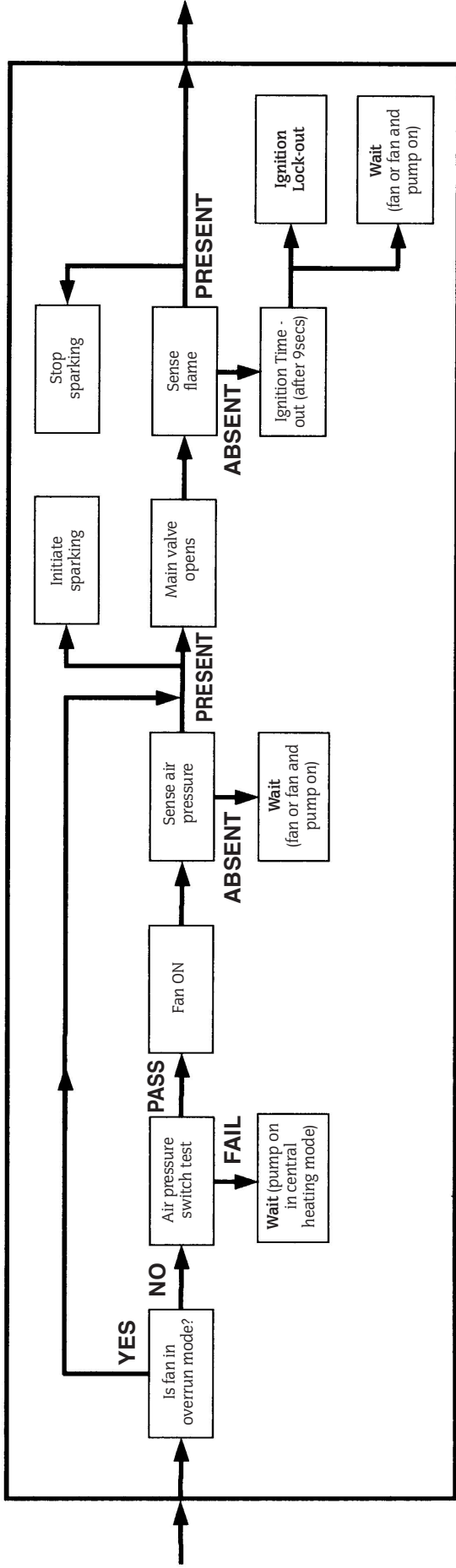

2. Domestic Hot Water Mode

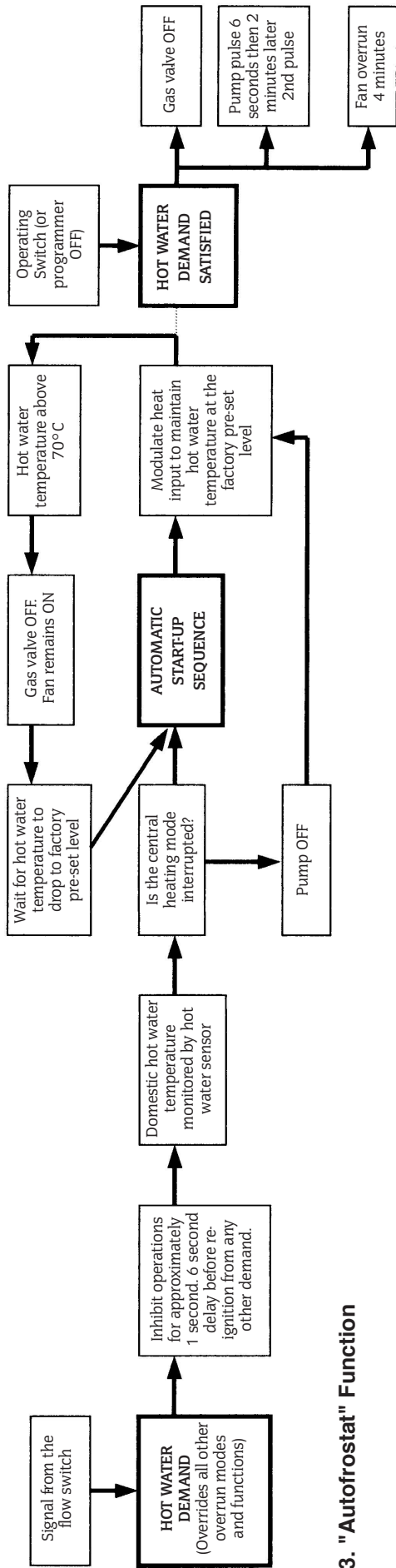

3. "Autofrost" Function

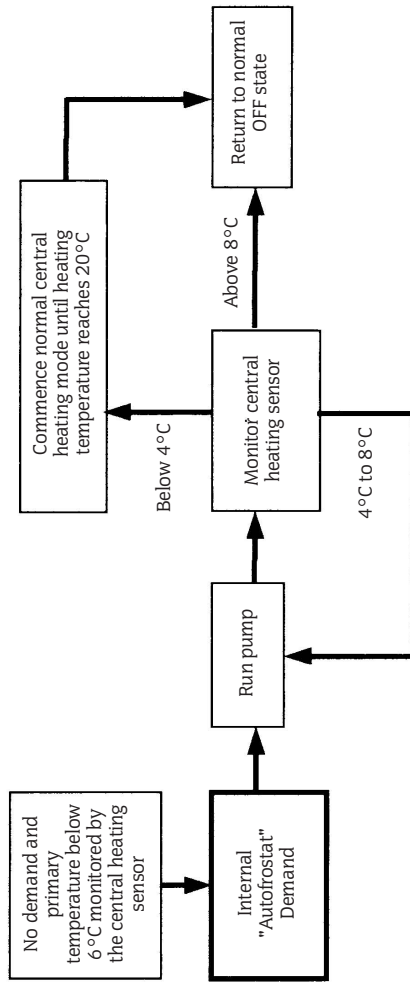

4. Pump Overrun Function

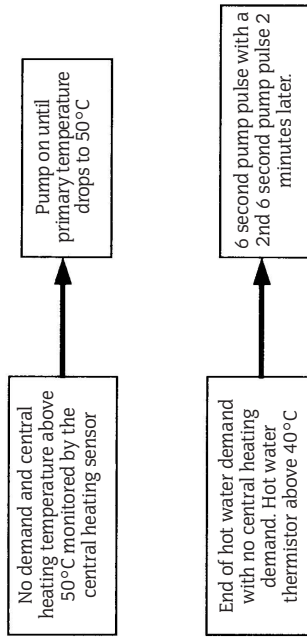

6. Central Heating ramp control

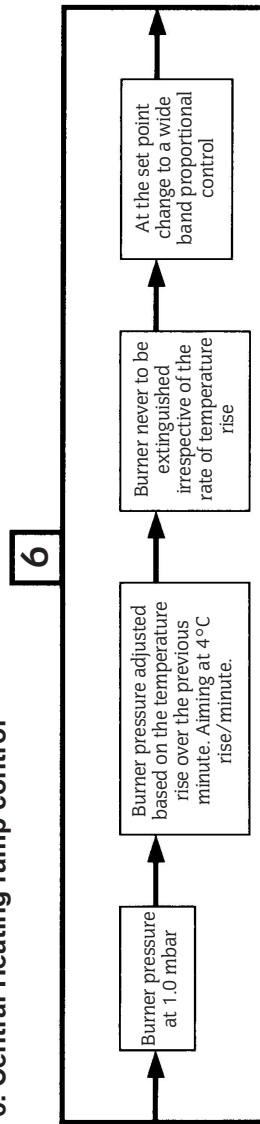

5. Fan Overrun Function

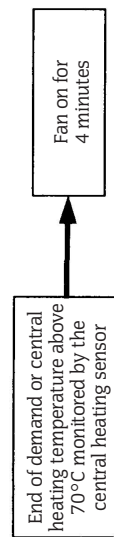

18. Fault Finding

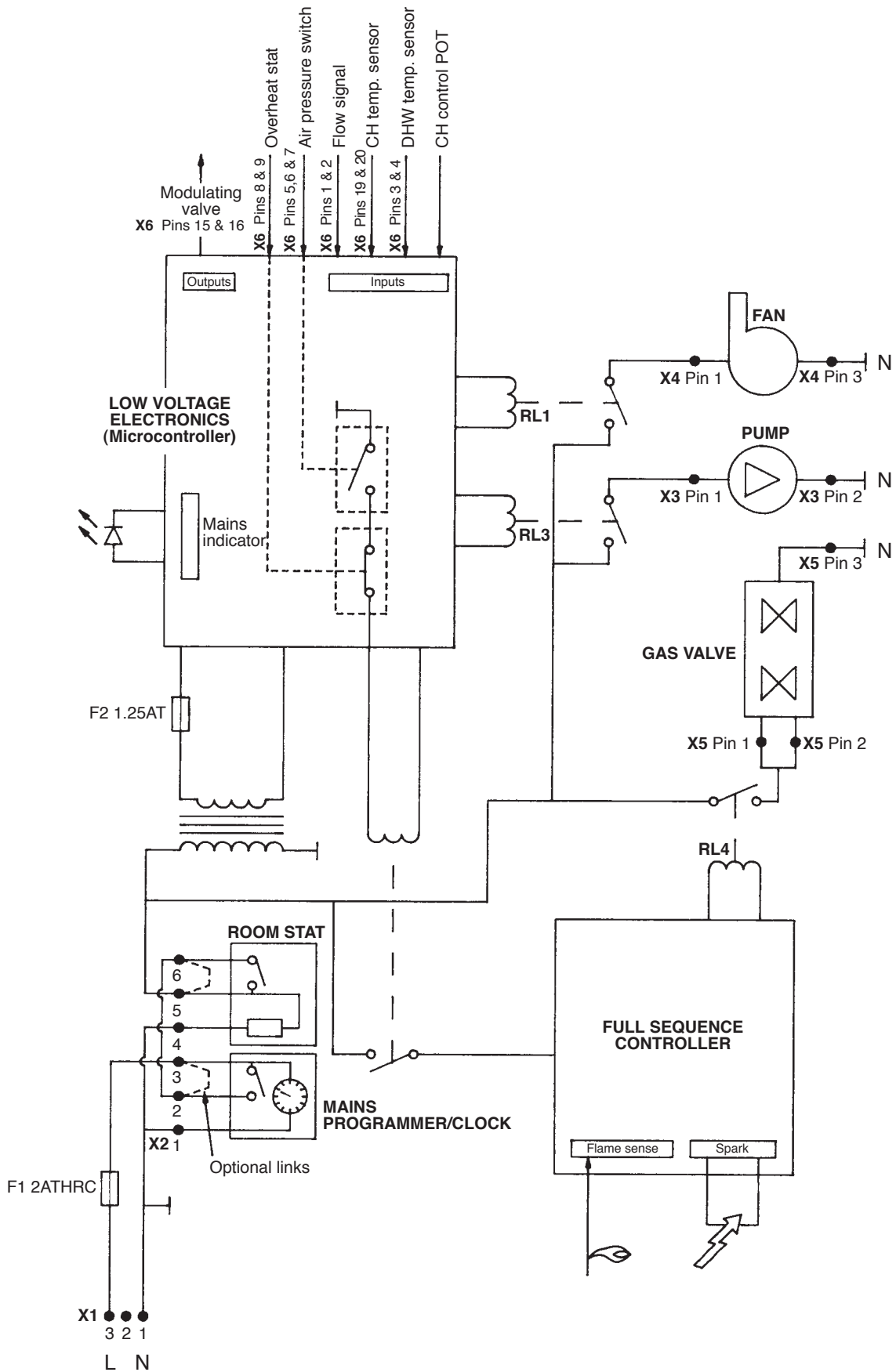

A

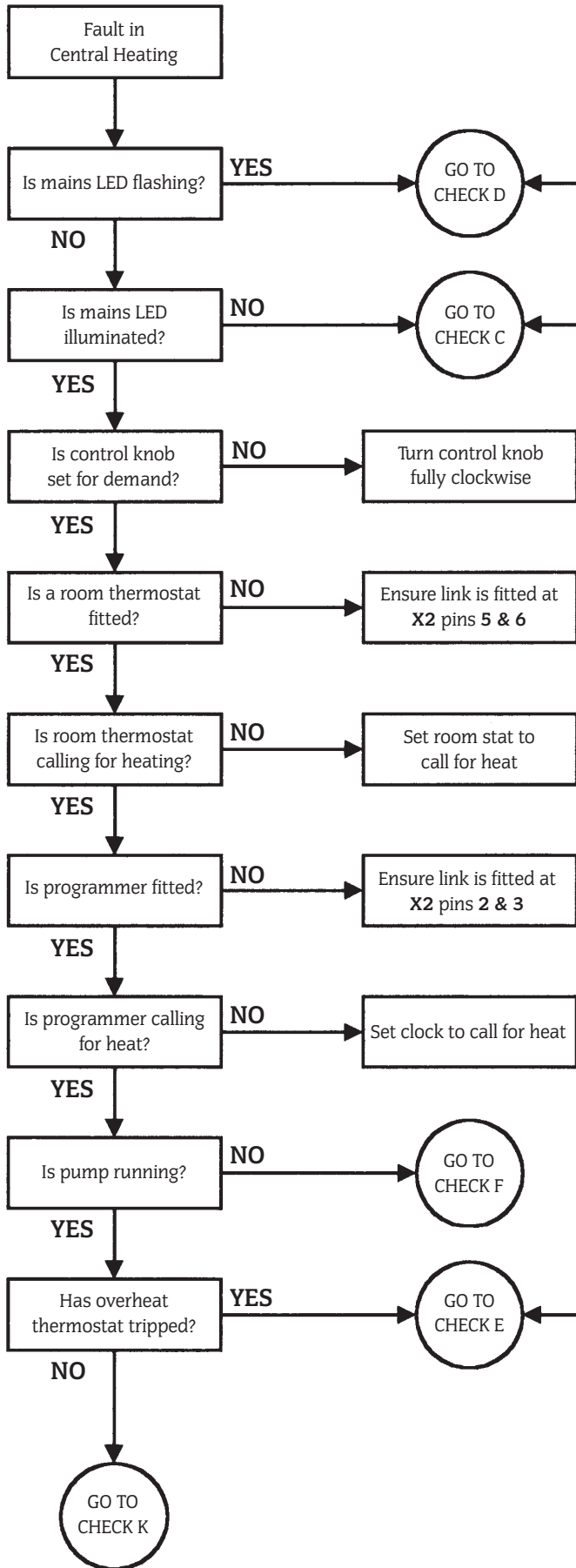

B

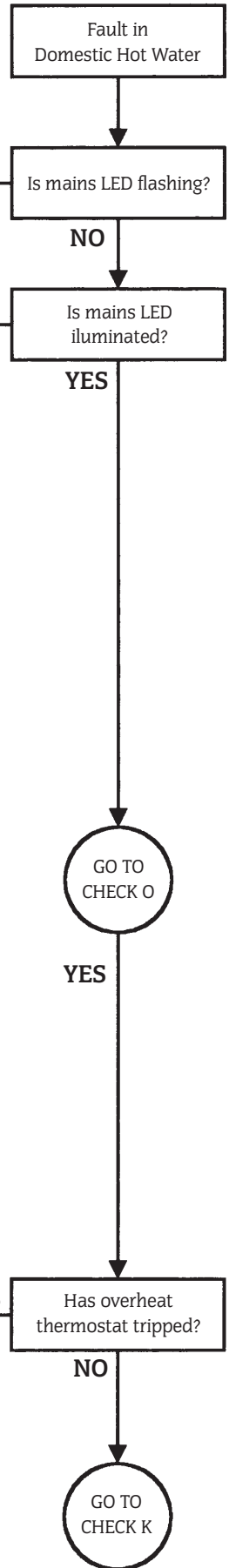

C

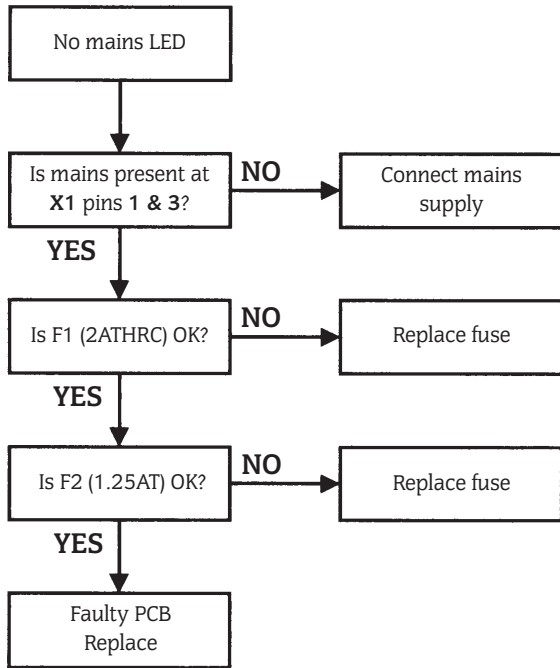

D

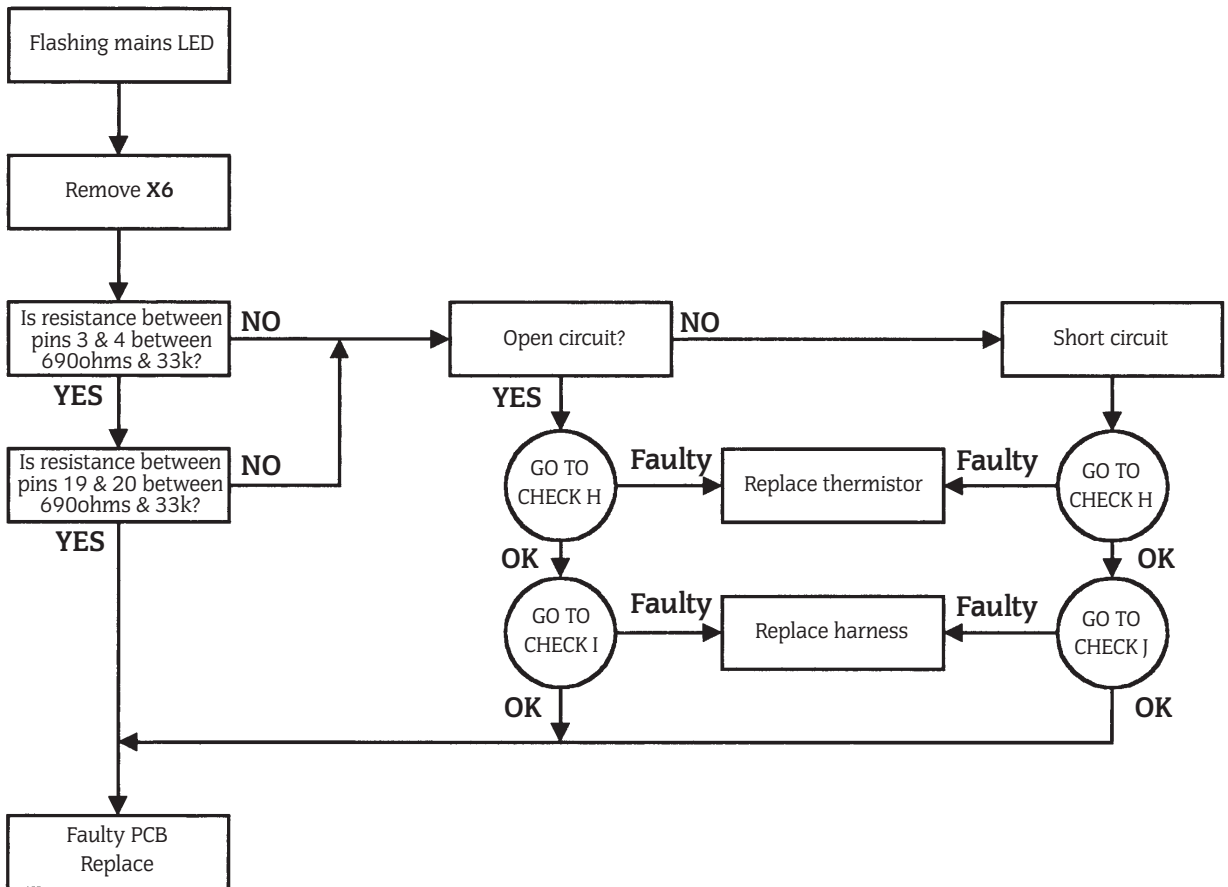

Overheat Thermostat Check

E

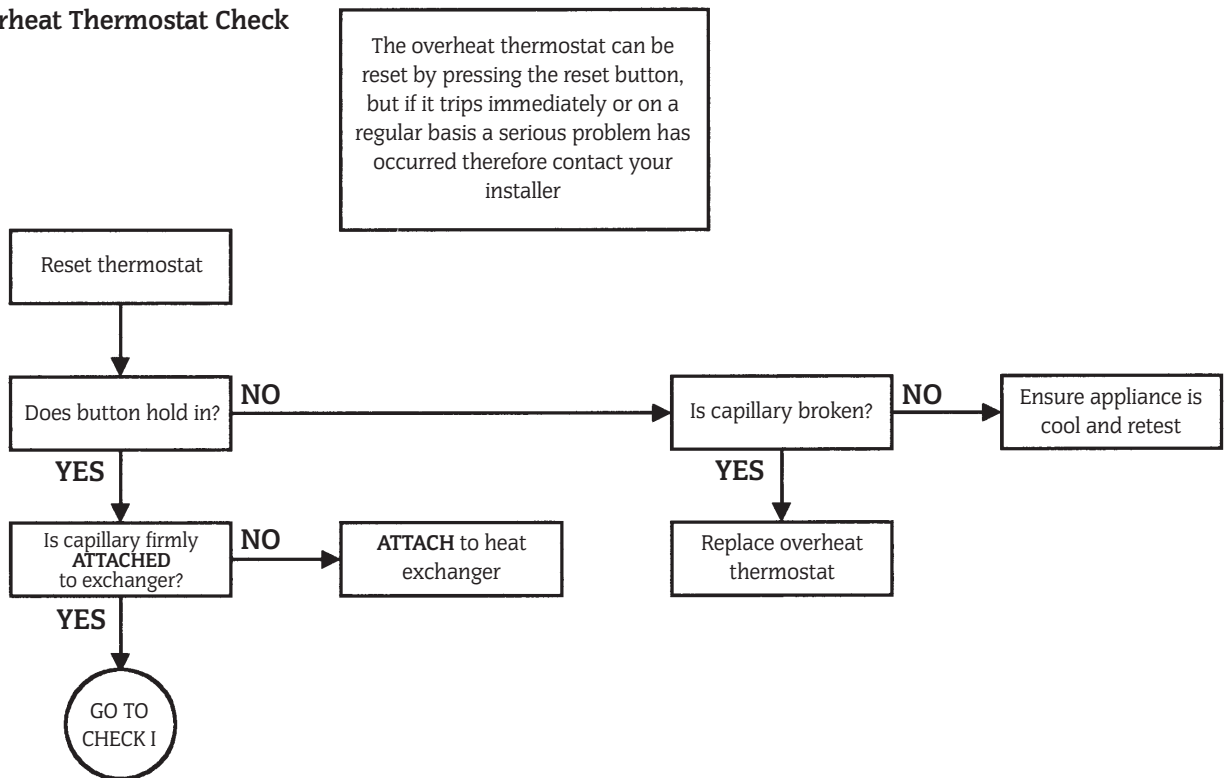

F

Pump Check

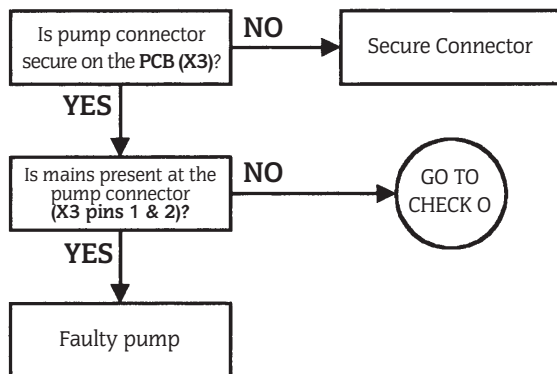

G

Fan Check

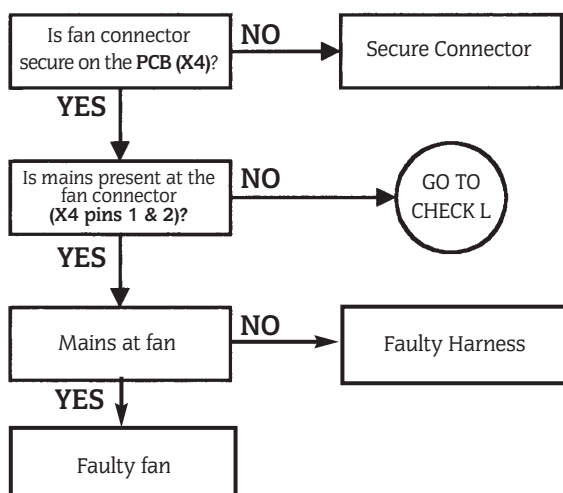

H Thermistor Check

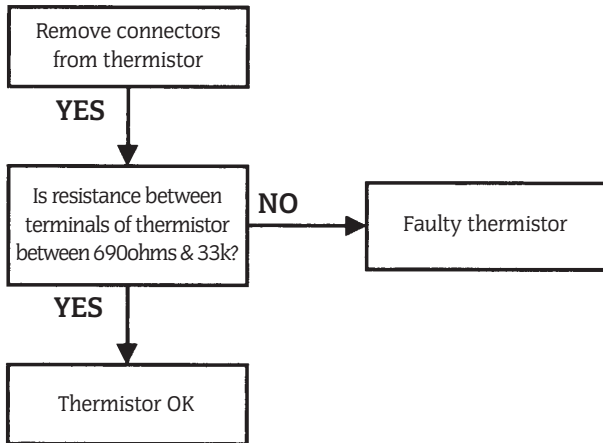

I Harness Continuity Check

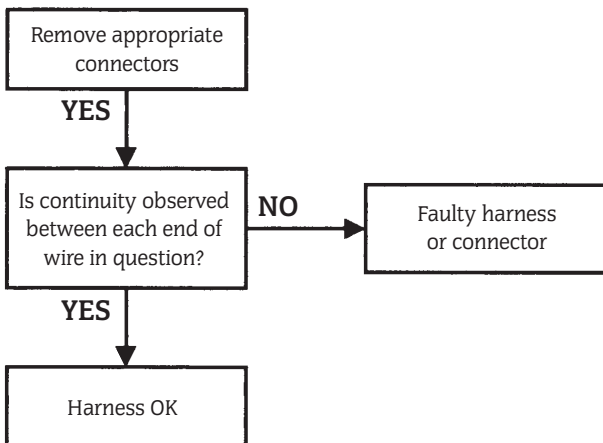

J Harness Short Check

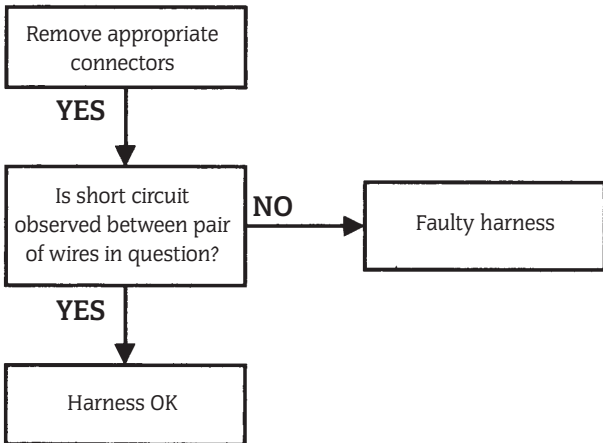

K

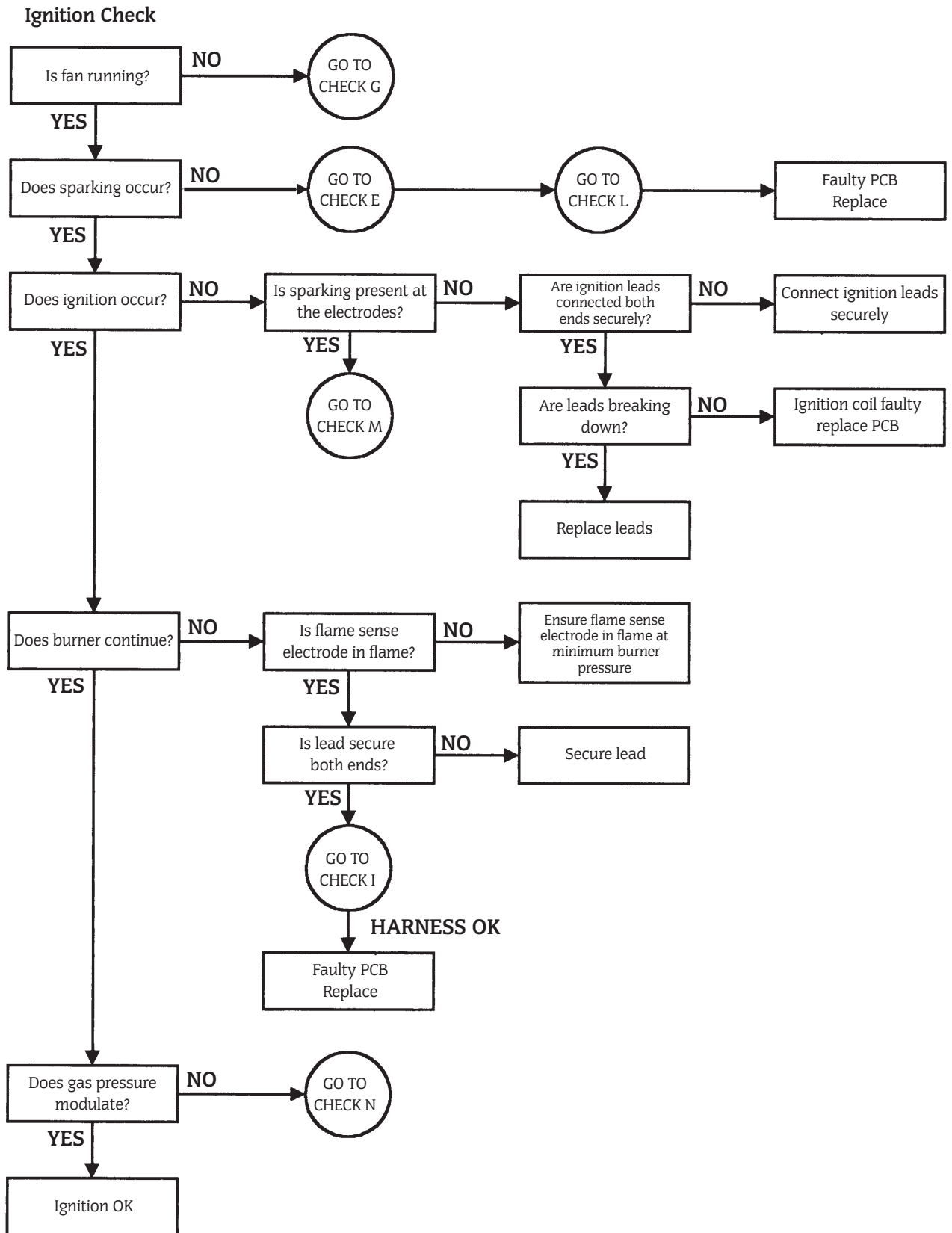

L

Air Pressure Switch Check

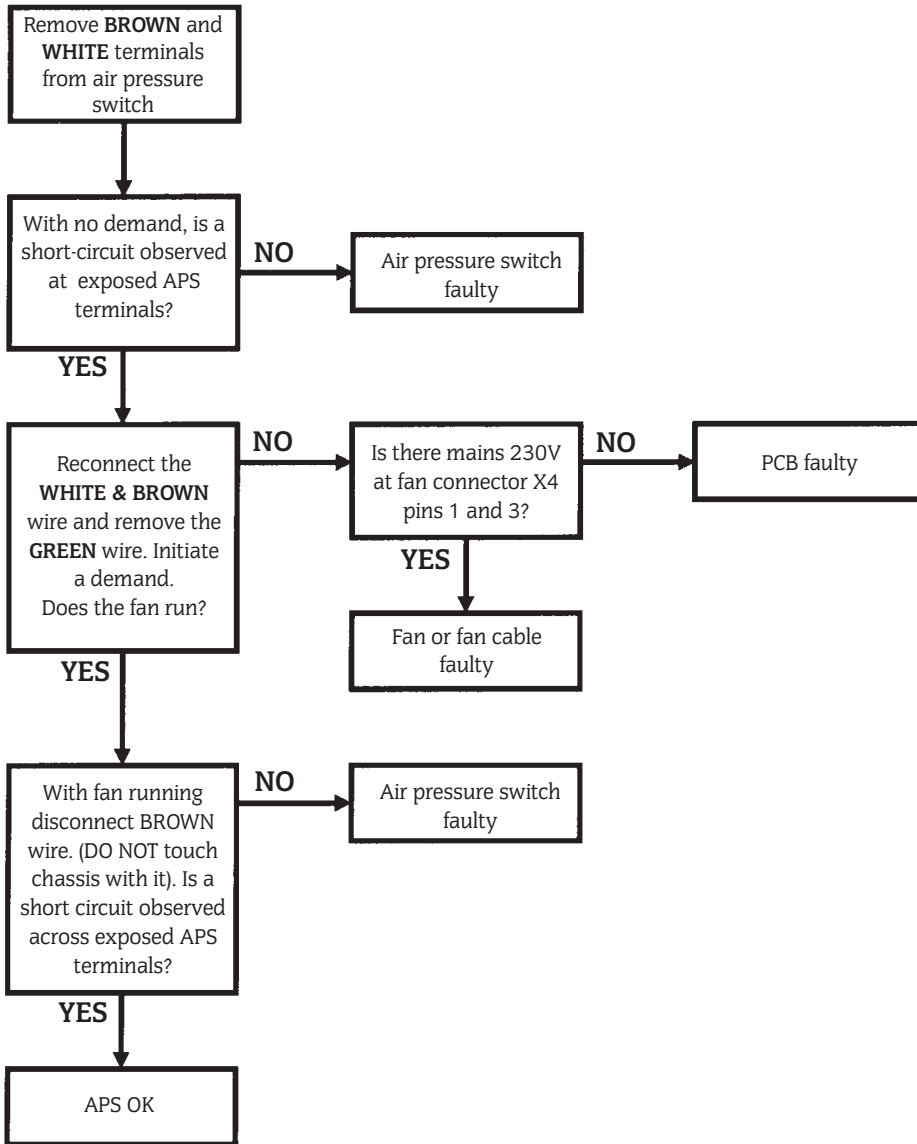

M

Gas Valve Check

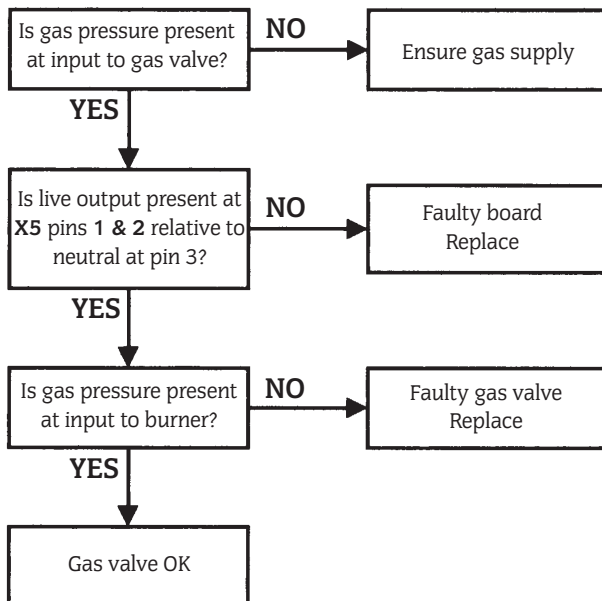

N Modulating Valve Check

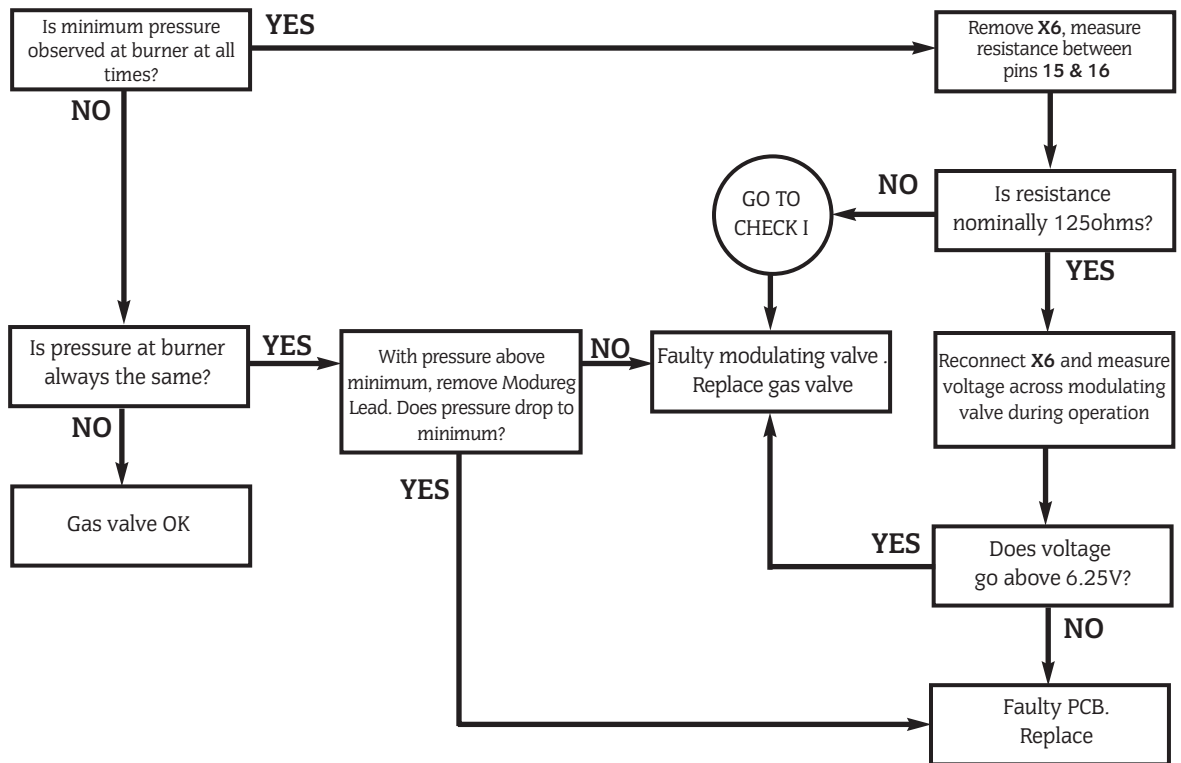

O Flow Switch Check

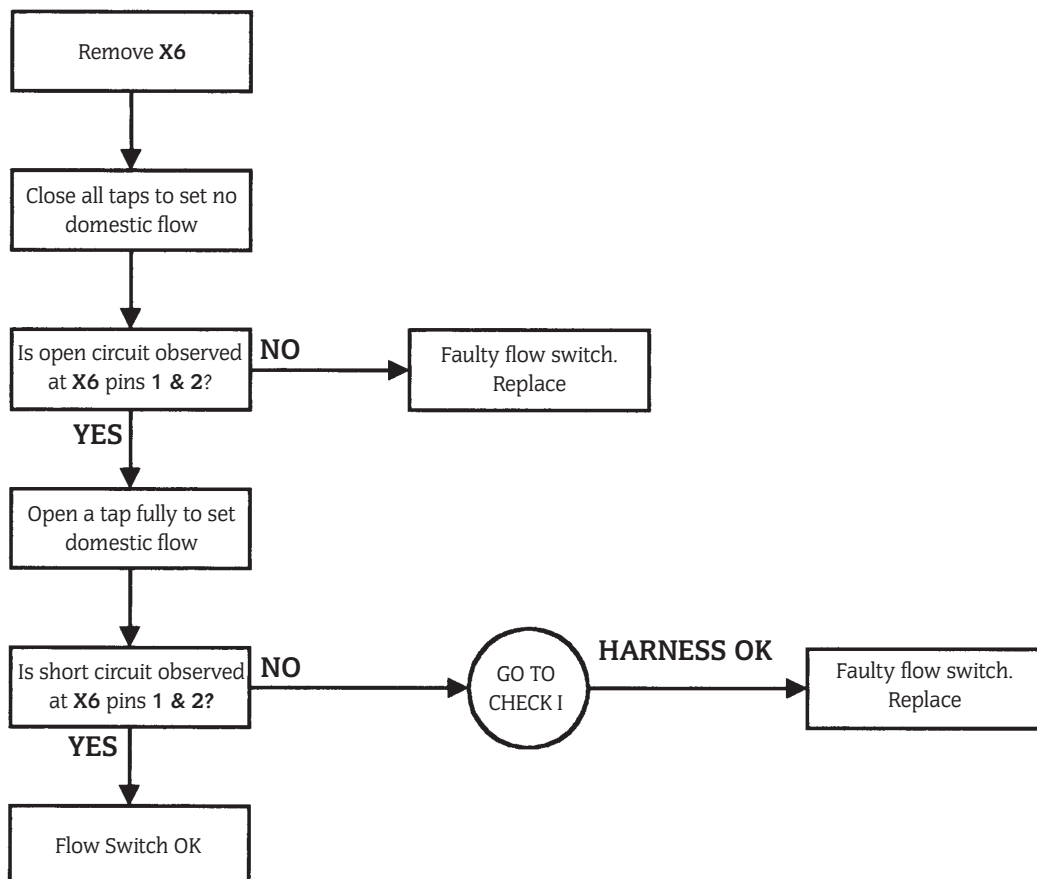

19. Component Parts List

Key No.	G.C. No.	Part	Manufacturer's Reference	Qty	WHS Part No.
1	E01-579	Burner Assembly Natural Gas	Aeromatic AC23/053586	1	8 716 142 604 0
	E01-580	Burner Assembly LPG	Aeromatic AC23/053587	1	8 716 142 611 0
2	E01-591	Injector Natural Gas	Stereomatic Ø 4.3mm	1	8 716 105 033 0
	E00-741	Injector LPG	Stereomatic Ø 2.78mm	1	8 716 140 209 0
3	E01-892	Gas Valve Natural Gas	SIT	1	8 716 142 413 0
	E01-893	Gas Valve LPG	SIT	1	8 716 142 430 0
4	E01-596	Air Pressure Switch	Huba 605.99484	1	8 716 142 414 0
5	375 697	Spark Electrode Assembly	Bucclench	1	8 716 142 100 0
6	E01-612	Flame Sensor	Bucclench	1	8 716 120 345 0
	E01-930	Flame Sensor Harness		1	8 716 120 126 0
7	E01-598	Ignition Harness	Bucclench	1	8 716 120 236 0
8	E01-599	Gas to Water Heat Exchanger	Giannoni	1	8 716 142 905 0
9	E01-600	Insulation Pack	WHS	1	7 716 192 216 0
10	E01-601	Auto Air Vent	Intermes	1	8 716 140 504 0
11	299-506	Pressure Gauge	Cewal	1	8 716 142 300 0
12	375 699	Pressure Relief Valve	Caleffi 3141 3bar	1	8 716 142 404 0
13	E01-602	Pump with Harness	Grundfos 15 60 special	1	8 716 143 107 0
14	E01-603	Expansion Vessel (8Ltr) 389mm Dia	Winkelman Panhof	1	8 716 142 502 0
15	E01-604	PCB Boiler Control	Pactrol	1	8 716 146 300 0
16	E04-582	Temperature Thermistors	Elmwood	2	8 716 142 384 0
	E01-900	CH Thermistor Clip		1	8 716 148 313 0
	299-495	DHW Thermistor Clip		1	8 716 148 303 0
18	E01-605	DHW Flow Regulator		1	8 716 141 052 0
19	324-822	Gauze Filter	WHS	1	8 716 148 401 0
20	299-363	Flow Sensor	WHS	1	8 716 141 000 0
21	E01-606	Fan Assembly	SIFAN	1	8 716 120 993 0
22	E01-607	Safety Temperature Limiter	Ranco LM7	1	8 716 142 307 0
23	E01-886	Flow Switch Assembly	SIKA	1	8 716 120 971 0
24	299-357	Fuse Pack	WHS	1	7 716 192 206 0
25	E01-610	Gasket Pack	WHS	1	7 716 192 218 0
ACCESSORIES					
	299-360	Mechanical Programmer Kit	DIEHL		7 716 192 002
	E01-940	Gas Conversion Kit	NG to LPG		7 716 192 131
	E01-941	Gas Conversion Kit	LPG to NG		7 716 192 132
	E05-341	Mini Expansion Vessel Kit	Including new pipe and Expansion Vessel		7 716 192 188
FLUE OPTIONS					
		Telescopic Horizontal Flue Kit	425 - 725mm		7 716 191 068
	E01-943	Extension Flue Kit	750 mm		7 716 191 006
	E01-944	Vertical Flue Kit			7 716 191 069
	E01-945	Vertical Flue Adaptor			7 716 191 016
	E01-946	Internal Fixing Kit	Telescopic Flue		7 716 191 019
	E01-058	Flue Elbow Kit	90 deg.		7 716 191 013
	E01-059	Flue Elbow Kit	45 deg.		7 716 191 014

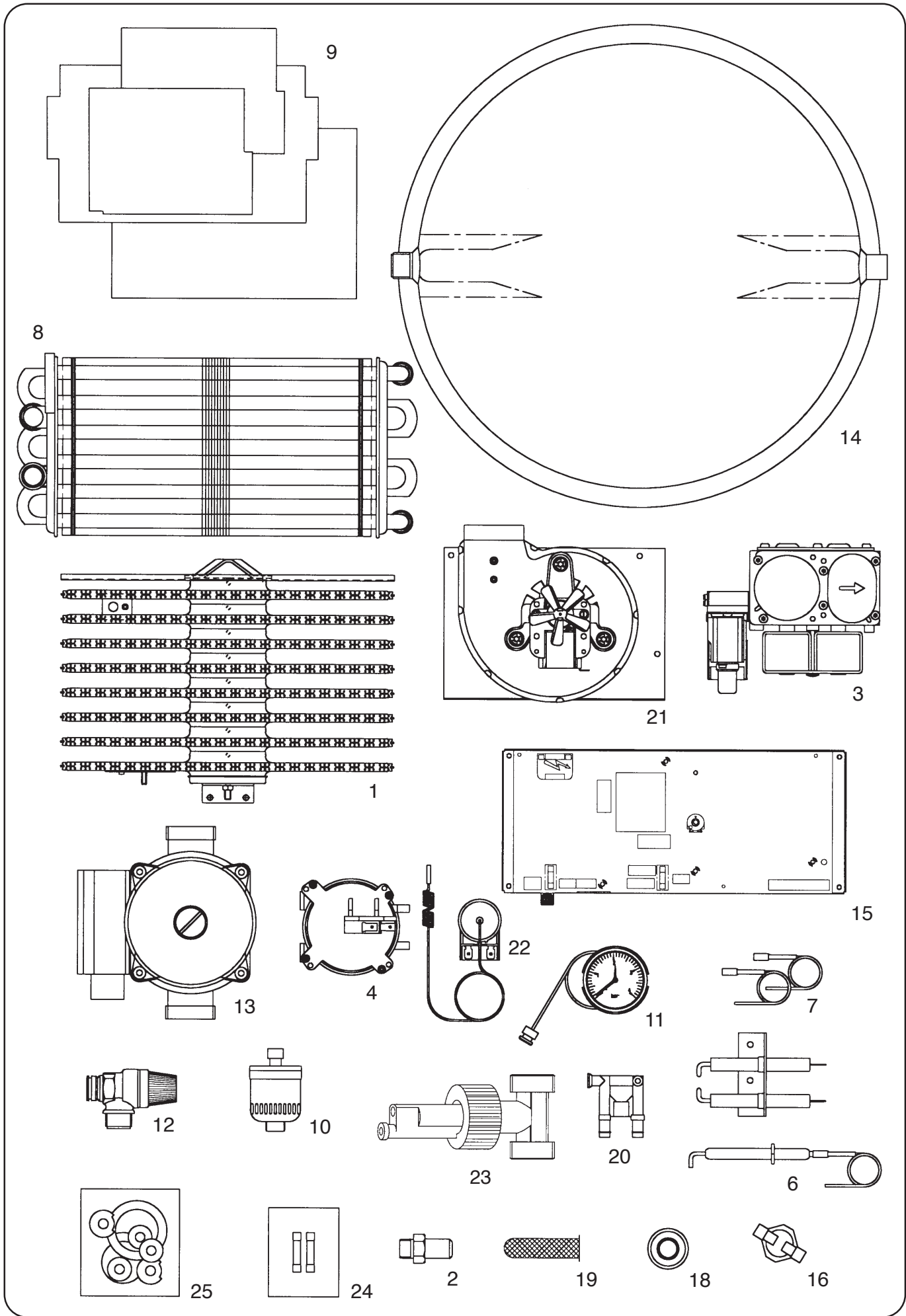

This manual is to be used in conjunction with the variant part number of the bar code below:



Worcester Heat Systems Limited (Bosch Group), Cotswold Way, Warndon, Worcester WR4 9SW.
Telephone: (01905) 754624. Fax: (01905) 754619.
Technical Helpline 08705 266241.
www.worcester-bosch.co.uk

This booklet is accurate at the date of printing but will be superseded and should be disregarded if specifications and/or appearances are changed in the interests of continued improvement.

All goods sold are subject to our official Conditions of Sale, a copy of which may be obtained on application.

PUBLICATION 8 716 115 050a (05/08)