

504/2



**WORCESTER  
BOSCH**

# 240 Combi OF

WALL MOUNTED COMBINATION BOILER FOR CENTRAL HEATING AND  
MAINS FED DOMESTIC HOT WATER

## INSTALLATION AND SERVICING INSTRUCTIONS

**IMPORTANT:-**   
SUPPLEMENT   
INCLUDED AT   
BACK OF BOOKLET

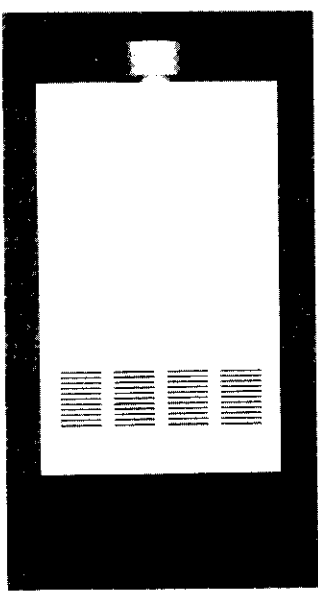

GC NUMBER 47 311 09

### BOILER OUTPUT

Automatic Modulating Control

To Domestic Hot Water and Central Heating  
Minimum 9.2 kW (31,400 Btu/h)  
Maximum 24.0 kW (82,000 Btu/h)

**IMPORTANT: THIS APPLIANCE IS FOR USE WITH NATURAL GAS ONLY**  
**THESE INSTRUCTIONS APPLY IN THE UK ONLY**  
**THESE INSTRUCTIONS ARE TO BE LEFT WITH THE USER OR AT THE GAS METER**

# Contents

1. Installation Requirements .....	Page 2	10. Electrical .....	Page 10
2. General Information .....	Page 2	11. Installation .....	Page 13
3. Technical Data .....	Page 4	12. Commissioning .....	Page 15
4. Siting the Appliance .....	Page 5	13. Instructions to the User .....	Page 16
5. Siting the Flue Terminal .....	Page 6	14. Inspection and Servicing .....	Page 17
6. Air Supply .....	Page 6	15. Replacement of Parts .....	Page 19
7. Sealed System .....	Page 7	16. Short Parts List .....	Page 25
8. Open Vent Primary Water System .....	Page 8	17. Operational Flow Diagram .....	Page 26
9. Domestic Hot Water .....	Page 8	18. Fault Finding .....	Page 28

## 1. Installation Regulations

### 1.1 Gas Safety (Installation and Use) Regulations 1984

All gas appliances must be installed by a competent person in accordance with the above regulations. Failure to install appliances correctly could lead to prosecution.

1.2 The manufacturers notes must not be taken, in any way, as overriding statutory obligations.

1.3 The compliance with a British Standard does not, of itself, confer immunity from legal obligations. In particular the installation of this appliance must be in accordance with the relevant requirements of the Gas Safety (Installation and Use) Regulations 1984 as amended, current IEE Wiring Regulations, local Building Regulations, Building Standards (Scotland)(Consolidation) and byelaws of the local Water Company. Health and Safety Document No. 635 (Electricity at Work Regulations). It should be in accordance with the relevant recommendations of the following British Standards.

BS 6798:1987 Specification for installation of gas fired hot water boilers of rated input not exceeding 60 kW.

BS 5449:1990 Central Heating for Domestic Premises.

BS 5546:1990 Installation of gas hot water supplies for domestic purposes.

BS 5440:1:1990 Flues and Ventilation for gas appliances of rated input not exceeding 60 kW: Flues.

BS 5440:2:1989 Flues and Ventilation for gas appliances of rated input not exceeding 60kW: Air Supply.

BS 6891:1988 Installation of low pressure gas pipework installations up to 28 mm (R1).

1.4 To ensure that the installation will perform to the highest standards, the system and components should conform to any other relevant British Standards in addition to those mentioned in the instructions.

## 2. General Information

2.1 This appliance is not suitable for external installation.

2.2 The appliance controls are set to provide a maximum output for the domestic hot water of 24 kW and a central heating load of up to 16.1 kW.

2.3 The appliance has a permanent pilot.

2.4 **PRINCIPLE APPLIANCE COMPONENTS** See Fig. 1.

A low thermal capacity Gas to Water heat exchanger.

A Water to Water heat exchanger to provide domestic hot water.

Fully modulating controls in the central heating and domestic hot water modes of operation.

An expansion vessel, pressure gauge and pressure relief valve.

A by-pass for the central heating system.

Temperature safety cut-out controls.

A water flow regulator.

An optional fascia mounted programmer instead of the standard Operating Switch.

### 2.5 ELECTRICAL SUPPLY

Mains supply: 240V ~, 50 Hz, 150 watts. External fuse 3A. Internal fuses: T2A (F1) and T315mA (F2).

### 2.6 GAS SUPPLY

The boiler requires 2.82 m<sup>3</sup>/h (96.8 ft<sup>3</sup>/hr) of gas. The gas meter and supply pipes must be capable of supplying this quantity of gas in addition to the demand from any other appliances being served. The table below gives an indication of limiting gas pipe lengths and the allowance to be made for fittings. Refer to BS6891 for further information.

The meter governor should deliver a dynamic pressure of 20 mbar (8in wg.) at the appliance.

The complete installation, including the gas meter, must be tested for soundness and purged. Refer to BS 6891.

TOTAL LENGTH OF GAS SUPPLY PIPE (metres)			Pipe Diameter (mm)
3	6	9	
Gas Discharge Rate (m <sup>3</sup> /h)			
2.9	-	-	15
8.7	5.8	4.6	22
18.0	12.0	9.4	28

#### Note:

Each fitting used in the gas line from the meter is equivalent to a length of straight pipe which must be added to the straight pipe length to give the total length.

ie: Elbow = 0.5 metres, Tee = 0.5 metres, 90° Bend = 0.3 metres.

### 2.7 GENERAL INSTALLATION

The appliance is supplied for connection to a sealed system but is suitable for use with an open vent system. The connections are supplied as an optional kit.

The specified ventilation openings must not be obstructed.

Do not place anything on top of the appliance.

The clearances specified for servicing must be maintained.

### 2.8 FLUE

The flue must be generally vertical and have no horizontal runs. The flue must end with a British Gas approved terminal.

### 2.9 CONTROLS

The electronic control system and gas valve modulate the heat input in response to the central heating and domestic hot water temperature settings between minimum and maximum.

The Operating Switch provides for the selection of domestic hot

**Fig. 1. Appliance water flow diagram.**

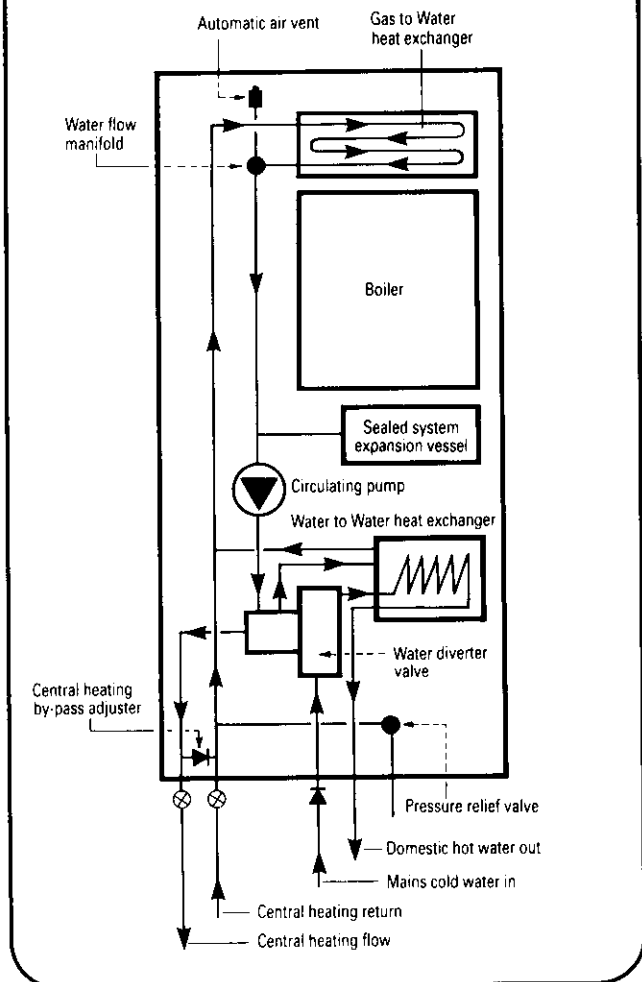

water only (**WATER**) or central heating and domestic hot water (**HEATING & WATER**) or **OFF**.

A facia mounted programmer is available as an optional extra. A remote mounted programmer may be connected to the appliance.

The integral facia displays indicate the status of the appliance.

There is provision for the connection of a mains voltage room thermostat and/or a frost thermostat.

The electronic controls prevent rapid cycling of the appliance in the central heating mode.

## 2.10 SYSTEM NOTES

### WARNING

**Check that no dirt is left in either the gas and water pipework as this could cause damage to the appliance. Thoroughly flush the heating system and the cold water mains supply. Purge the gas supply before finally connecting the appliance..**

The water pipe connections throughout a sealed system must be capable of sustaining a pressure of upto 3 bar.

Radiator valves must conform to the requirements of BS2767 (10): 1972.

The relief valve discharge must be directed away from any electrical components or where it would cause a hazard to the user.

A drain cock to BS 2879 must be fitted to the lowest point of the system.

For circuit design purposes it is important that due note is taken of the information given in Table 3 relating to the available pump head.

## 2.11 SHOWERS, BIDETS, TAPS AND MIXING VALVES

Hot and cold taps and mixing valves used in the system must be suitable for operating at a mains pressure of up to 10 bar.

Thermostatically controlled or pressure equalising shower valves will guard against the flow of water at too high a temperature.

Hot and cold mains fed water can be supplied direct to an over-rim flushing bidet subject to local Water Company requirements.

With all mains fed systems the flow of water from the individual taps will vary with the number of outlets operated simultaneously and the cold water mains supply pressure to the property. Flow balancing using 'Ball-o-Fix' type valves is recommended to avoid an excessive reduction in flow or even starvation to individual outlets. For further information contact Worcester Heat Systems Ltd.

## 2.12 SAFETY CONSIDERATIONS

The appliance must not be operated in a waterless condition.

The appliance must not be operated with the boiler inner casing cover removed.

Work must not be carried out on the appliance without the gas and electricity supplies being switched off.

Checks must be made to ensure that the ventilation openings made into walls and partitions are of the correct size and are not obstructed.

## 2.13 OPERATION

**Domestic Hot Water:** With a demand for hot water the burner will light at its maximum setting and then automatically adjust its output to maintain the temperature rise of the delivered water. When hot water is no longer required, the burner will extinguish. The pump will continue to run for a short period to dissipate the residual heat from the appliance.

**Central Heating:** With a demand for heating the burner will light at its minimum setting and gradually increase to give the maximum output. The output of the appliance is then automatically adjusted to maintain the temperature of the system. The output can reduce down to a minimum of 9.2 kW. If the system no longer requires even the minimum output to maintain the desired room temperature the burner will extinguish. The pump will continue to run to dissipate the residual heat from the appliance. The appliance will remain off for a fixed period of two minutes before re-lighting to automatically meet the system requirements.

**Domestic Hot Water and Central Heating:** The appliance will supply heat to the central heating system as required. A demand for domestic hot water at a tap or shower will override the central heating requirement for the period of the domestic hot water demand. When hot water is no longer required the burner will extinguish and the appliance will return to the central heating state and its normal mode of operation. The pump will continue to run to dissipate the residual heat from the appliance as necessary.

### 3. Technical Data

The Data Plate is fixed to the control box casing.

TABLE 1

NOMINAL BOILER RATINGS							
Output		Input		Burner Setting Pressure		Gas Rate	
kW	Btu/h	kW	Btu/h	m bar.	in. wg.	m <sup>3</sup> /h	ft <sup>3</sup> /h
9.2	31,400	12.6	43,000	2.7	1.1	1.17	40.2
16.1	54,900	21.2	72,300	7.3	2.9	2.03	69.6
24.0	82,000	30.1	102,700	15.0	6.0	2.82	96.8

TABLE 5

Flue Diameter	125 mm
Flue Pipe	BS 4543

TABLE 2

AVAILABLE PUMP HEAD						
Boiler Output		Head		Min. Flow Rate		Temp. rise across heating flow and return
kW	Btu/h	metres	feet	litres/min	gal/min	
9.2	31,400	4.9	15.9	12.0	2.64	11°C (20°F)
16.1	54,900	2.54	8.25	23.0	5.07	11°C (20°F)
24.0	82,000	2.0	6.5	23.0	5.07	15°C (28°F)

TABLE 3

SPECIFICATIONS	
CENTRAL HEATING FLOW FITTING	22 mm Compression
CENTRAL HEATING RETURN FITTING	22 mm Compression
COLD WATER MAINS INLET FITTING	15 mm Compression
DOMESTIC HOT WATER OUTLET FITTING	15 mm Compression
GAS INLET FITTING	Rc1/2
PRESSURE RELIEF VALVE DISCHARGE FITTING	15 mm Compression
CASING HEIGHT	900 mm (35.4 in.)
CASING WIDTH	450 mm (17.7 in.)
CASING DEPTH	360 mm (14.2 in.)
WEIGHT (including water)	48 kg (105 lb)
INSTALLATION WEIGHT	46 kg (101 lb)
PACKAGED WEIGHT	49 kg (108 lb)

TABLE 4

SPECIFICATIONS	
PRIMARY WATER CAPACITY	2.7 litres (0.6 galls.)
MAXIMUM COLD SUPPLY PRESSURE	10 Bar (150 psi)
MINIMUM COLD SUPPLY PRESSURE (WORKING) FOR MAXIMUM HOT WATER FLOW	1.6 Bar (23.5 psi)
MINIMUM COLD SUPPLY PRESSURE (WORKING) TO OPERATE THE APPLIANCE	0.6 Bar (9 psi)
MAXIMUM CENTRAL HEATING FLOW TEMPERATURE	Nominally 82°C (180°F)
MAXIMUM STATIC HEAD (PRIMARY)	25 metres (81 ft)
MINIMUM STATIC HEAD (PRIMARY)	0.3 metres (1 ft)
OUTPUT TO DOMESTIC HOT WATER	Modulating 9.2–24.0 kW (31,400–82,000 Btu/h)
OUTPUT TO CENTRAL HEATING	Modulating 9.2–24.0 kW (31,400–82,000 Btu/h)
MAXIMUM DOMESTIC HOT WATER FLOW RATE FROM THE APPLIANCE	Nominally 8.5 litres/min (±15%) (1.87 gallons/min)
EQUIVALENT DOMESTIC HOT WATER FLOW RATE TO GIVE A TEMPERATURE RISE OF 35°C	Nominally 9.8 litres/min (2.16 gallons/min)

## 4. Siting The Appliance

4.1 The appliance must not be installed in any room containing a bath or shower or in a bedroom, bed-sitting room or garage. Particular attention is drawn to the requirements of the current I.E.E. Wiring Regulations and, in Scotland, the electrical provisions of the Building Regulations applicable in Scotland.

4.2 The appliance is not suitable for external installation.

4.3 The appliance does not require any special wall protection.

4.4 The wall must be capable of supporting the weight of the appliance. See Table 3.

4.5 If the appliance is to be fitted in a timber framed building, refer to the British Gas publication "Guide for Gas Installations in Timber Framed Housing".

4.6 The following clearances must be available for installation and for servicing. See Fig. 2.

	Installation	Servicing
Above	300 mm	300 mm
In front	600 mm	600 mm
Below *	900 mm	230 mm
Right hand side	100 mm	100 mm
Left hand side	100 mm	100 mm

4.7 No combustible surface must be within 75 mm of the casing. See BS476:4.

4.8 Always consider the possible need to disconnect the pipes from the appliance after installation.

4.9 Boilers in roof spaces or in understair locations require special conditions. Refer to BS 6798.

\* 4.10 The appliance must have a minimum clearance of 900 mm between the bottom of the appliance and the floor.

Fig. 2. Appliance casing dimensions and required clearances.

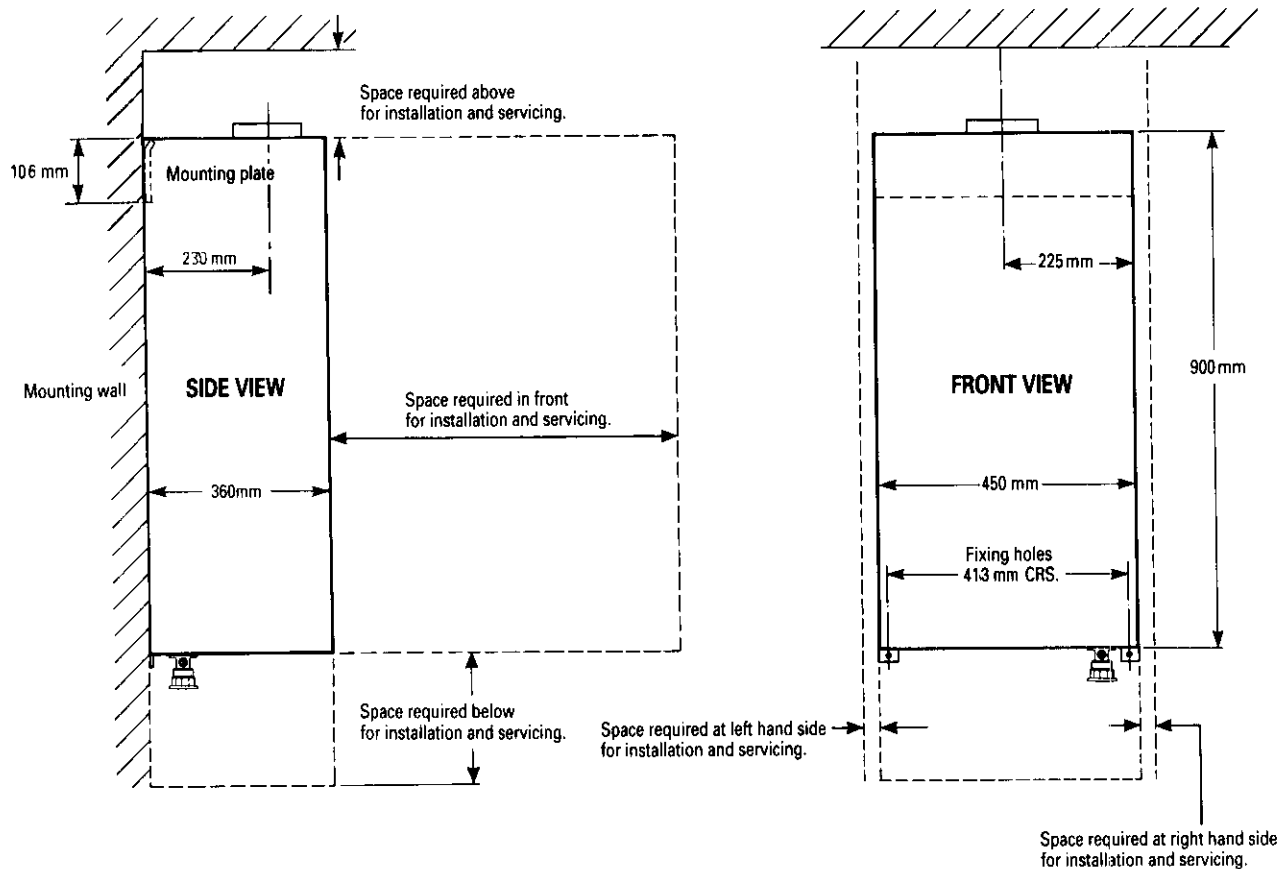

**Fig. 3. Appliance pipework connections.**

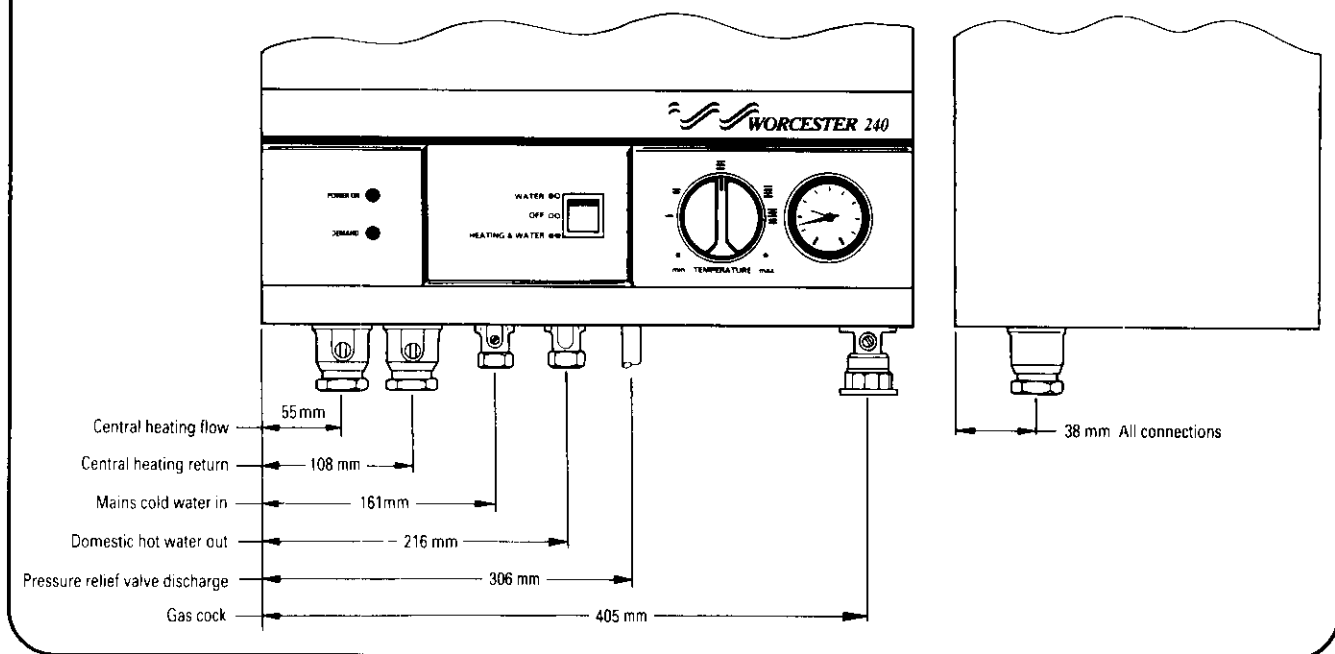

## 5. Siting the Flue Terminal

The flue diameter is 125 mm. Refer to BS 4543.

5.1 The flue must be installed as specified in BS 5440:Part 1.

5.2 A means of dis-connection of the flue should be provided and positioned immediately above the appliance draught diverter.

5.3 Horizontal flue runs should be avoided and the flue should terminate in accordance with the requirements of BS 5440:1. The terminal must be of a type approved by British Gas and must not be within 600 mm (24 in) of an openable window, air vent or other ventilation opening.

5.4 If the flue is to be taken through the wall behind the appliance then adequate space must be available to allow the fitting of a suitable flue bend. A right-angle bend is not acceptable. A minimum of 600 mm of vertical flue pipe is required before the introduction of a bend. If the flue is taken through the ceiling and into the roof-space or room above then a sleeve of non-combustible material allowing an air-space of at least 25 mm between the flue and the sleeve must be provided. The flue pipe must be held in the centre of the sleeve.

## 6. Air Supply

6.1 The room in which an appliance is installed must have a permanent air vent to outside air or to a room which itself has

direct access to outside air. The minimum effective area of the air vent(s) must be 104 cm<sup>2</sup>.

6.2 There must be sufficient clearance around the appliance to allow proper circulation of ventilation air. The clearances required for Installation and Servicing will normally be adequate for ventilation. See Section 4.6.

6.3 The minimum free areas required are given below.

Position of air vents	Air from the room	Air direct from outside
High Level	271 cm <sup>2</sup> . (42 in <sup>2</sup> .)	135.5 cm <sup>2</sup> . (21.5 in <sup>2</sup> .)
Low Level	542 cm <sup>2</sup> . (84 in <sup>2</sup> .)	271 cm <sup>2</sup> . (42 in <sup>2</sup> .)

6.4 Refer to BS 6798 and BS 5440:2 for additional information.

6.5 A spillage test, as detailed in BS5440:1, must be carried out and any remedial action taken to ensure that the installation meets the standard. The effect of any type of extract fan in the premises must be considered and an additional air inlet may be needed from outside to counter the effect of the fan.

## 7. Sealed System

- 7.1 The system must comply with the requirements of BS 6798 and BS 5449:1.
- 7.2 The appliance must not be operated without the system being full of water, properly vented and pressurised.
- 7.3 The pressure relief valve operates at 3 bar (45lb/in<sup>2</sup>). The discharge must be directed away from electrical components or where it might be a hazard to the user.
- 7.4 The pressure gauge indicates the system pressure which must be maintained.
- 7.5 The 10 litre expansion vessel is charged to 0.5 bar and is suitable for a static head of 5 metres (17.5ft). The pressure can be increased if the static head is greater than 5 metres (17.5ft).
- 7.6 With an initial system pressure of 0.5 bar, a system capacity of about 104 litres can be accommodated. Refer to BS 7074 Pt. 1 for more information. The charge pressure can be increased but with a decrease in system volume.
- 7.7 The filling point must be at low level. See Fig. 4.

- 7.8 Water loss must be replaced. See Fig 6. The connection should be made in the central heating return as close to the appliance as possible.
- 7.9 The make-up vessel, if fitted, must be fitted with a non-return valve.
- 7.10 Repeated venting loses water from the system. It is essential that this water is replaced and the system pressure maintained.
- 7.11 Connections to the mains water supply must not be made without the authority of the local Water Company.
- 7.12 The pump is set at maximum and must not be adjusted.
- 7.13 Connections in the system must resist a pressure of up to 3 bar.
- 7.14 Radiator valves must conform to BS 2767(10):1972.
- 7.15 Other valves used should conform to the requirements of BS 1010.
- 7.16 To make use of the extra heating available from the appliance at the end of any demand, it is recommended that a single small radiator be left permanently open.

Fig. 4 Sealed primary water system.

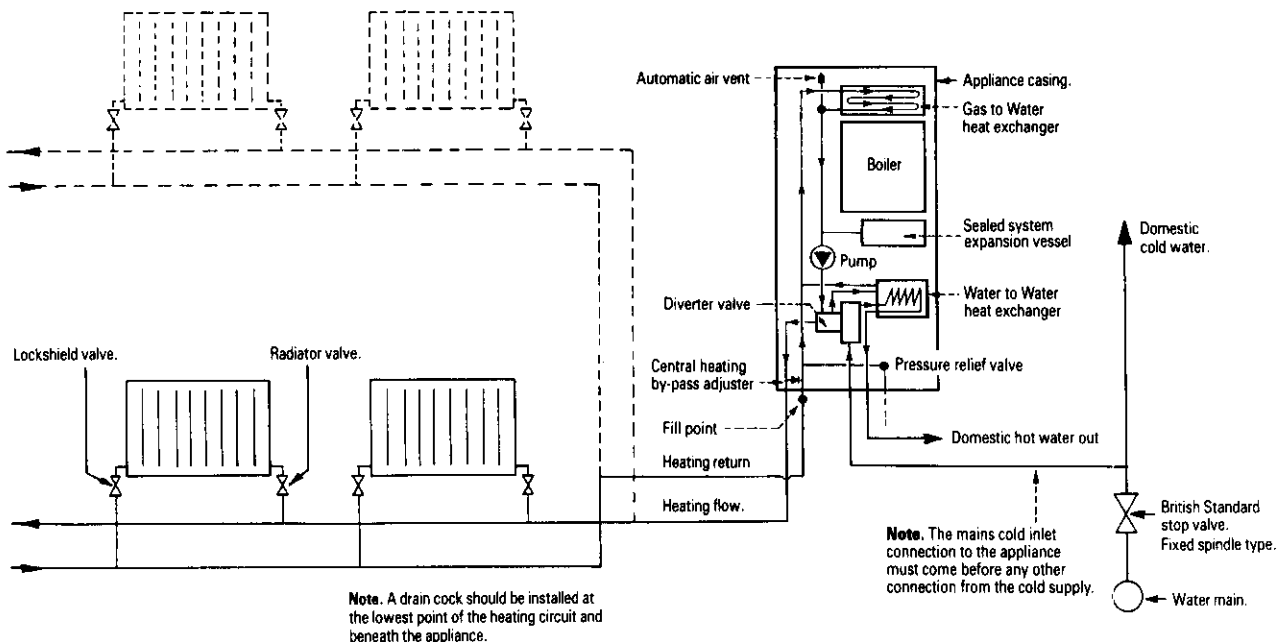
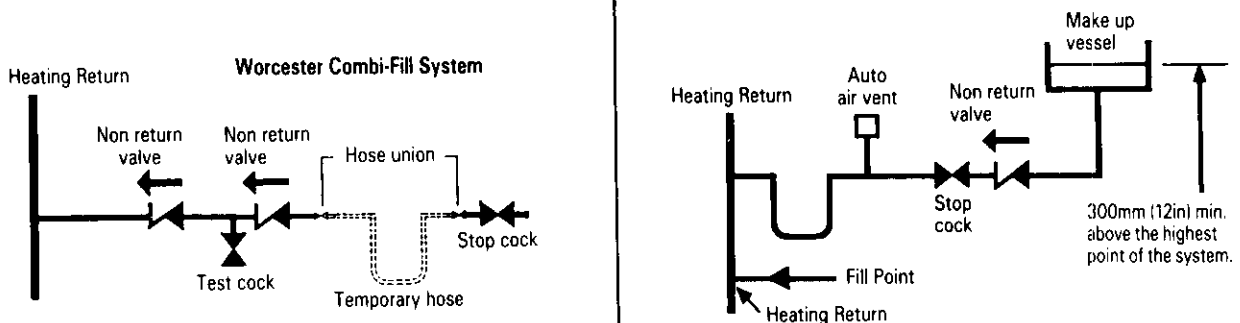

Fig. 5. System filling and make-up.



## 8. Open Vent Primary Water System

See Fig. 7

**8.1** The size of the flow and return pipework is given in Section 3 – Table 4. The components required to connect the appliance to an open vent system are available as an optional extra kit.

**8.2** The feed and expansion cistern should be arranged so that there is a minimum static head of 0.3 metres (12in.) above the top of the appliance or above the highest point in the heating circuit, whichever is the higher. See Fig. 6.

**8.3** The feed and vent pipe should be 22 mm diameter and rise continuously from the appliance to the feed and expansion cistern.

**8.4** A pressure relief valve is not required on an open vented system. If the pressure relief valve is left in position then a discharge pipe must be fitted which terminates in a position such that any water or steam discharge does not cause a hazard to the occupants or damage electrical components.

**8.5** Air within the appliance will be expelled via the feed and vent connection or dissipated into the rest of the system which must be fitted with manual air vents at any high point.

**8.6** The pump is set to maximum and must not be reset.

**8.7** To make use of the extra heating available from the appliance at the end of any demand, it is recommended that a single small radiator be left permanently open.

Fig. 6. Open vent water system.

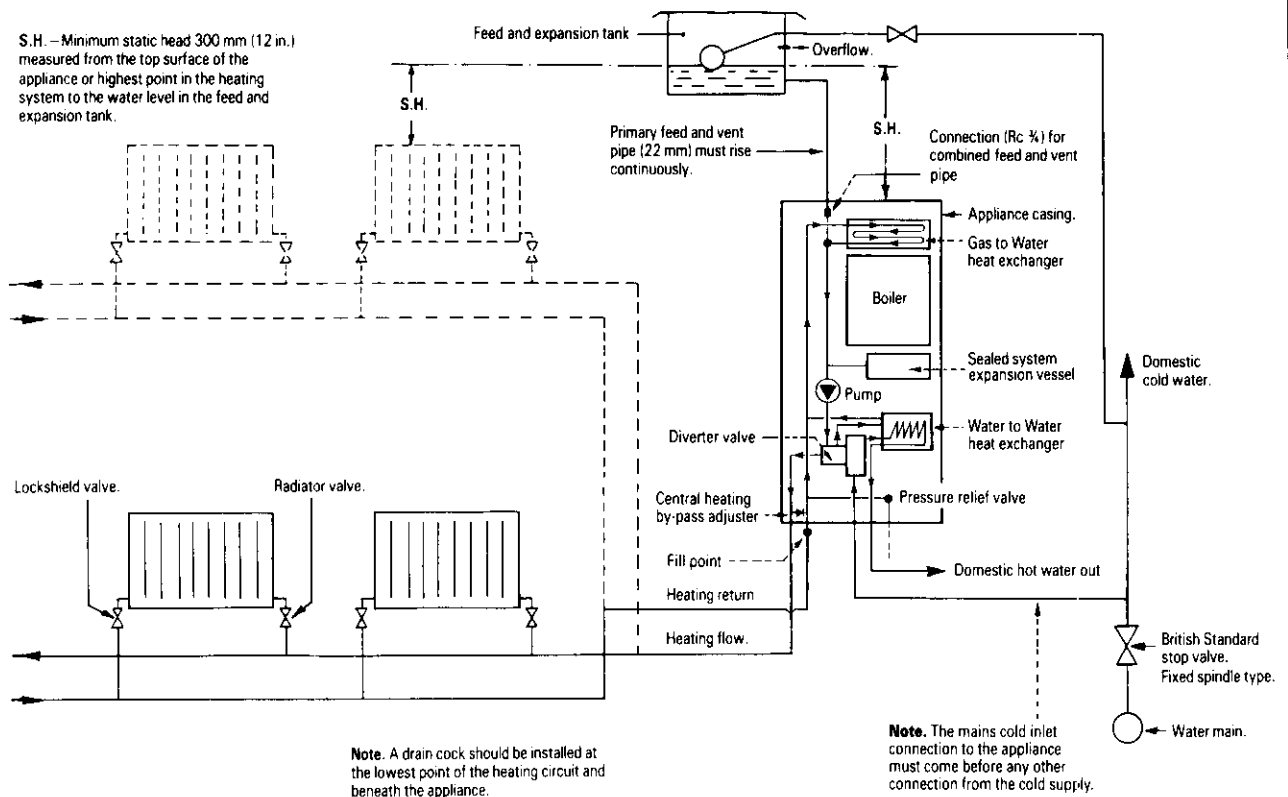

## 9. Domestic Hot Water

**9.1** The following are general requirements and, if necessary, reference should be made to the local Water Company before fitting the appliance.

**9.2 MAINS COLD WATER INLET.** Devices capable of preventing the flow of expansion water must not be fitted unless separate arrangements have been made. An expansion vessel connection point is provided within the appliance.

A 15mm connection is provided on the domestic water inlet elbow. A Zilmet Z160 is the preferred type. A thread sealant compatible with potable water must be used.

**9.3** The final 600 mm of the mains cold water connection to the appliance should be made in copper tube only.

**9.4** The appliance is suitable for a mains pressure of up to 10 bar (150 lb/in<sup>2</sup>).

**9.5** The appliance is fitted with a mains supply isolating valve.

**9.6** The maximum domestic hot water flow rate is 8.5 litres/min (± 15%) (1.87 gallons/min).

**9.7** In winter (when the mains inlet water temperature is lower) a reduced flow rate at the taps will be required to achieve the maximum hot water delivery temperature available in warmer weather.

**9.8** It is a requirement that long pipe runs to the taps or shower should be insulated to prevent the rapid cooling of domestic hot water after a tap or shower has been turned off. Refer to BS5546:1990.

Pipe diameter: up to 12mm. Max. length 20 metres.

Pipe diameter: up to 22mm. Max. length 12 metres.

**9.9** Hot and cold taps and mixing valves used with this appliance must be suitable for operating at a pressure of up to 10 bar (150 lb/in<sup>2</sup>).



**9.10** No anti-syphonage arrangements are necessary except for some loose head showers. See also Section 9.12 following.

**9.11** Thermostatically controlled or pressure equalising shower valves will guard against the flow of water at too high a temperature.

**9.12** The head of a loose head shower must not fall closer than 25mm (1in) above the top edge of the bath to prevent its immersion in bath water. Alternatively the shower must be fitted with an anti-syphonage device at the point of the flexible hose connections.

**9.13** The supply of hot and cold mains water direct to a bidet is permitted, (subject to local Water Company requirements), provided that the bidet is of the over-rim flushing type. The outlet(s)

should be shrouded and unable to have any temporary hand held spray attached. No anti-syphonage arrangements are necessary.

**9.14** As the maximum temperature of the Water to Water heat exchanger is limited by the control circuit, there is normally no need for water treatment to prevent scale accumulation. In exceptional circumstances a device to prevent scale formation can be fitted.

Installation of a scale inhibitor assembly should be in accordance with the requirements of the local Water Company. An isolating valve should be fitted to allow servicing. The water hardness can be determined using a standard test paper or by reference to the local Water Company.

## 10. Electrical

See Figs. 7, 8, 9, 10 and 11.

**10.1 MAINS SUPPLY.** 240 V ~, 50 Hz, 150 watts.

External Fuse 3A. Internal Fuses: T2A (F1) and T315mA (F2).

**10.2** It must be possible to completely isolate the appliance.

**10.3** Connection to the mains supply should be via a double pole isolator with a contact separation of 3mm in all poles and supplying the appliance and controls only.

**10.4** The appliance must be earthed.

**10.5 Mains Cable.** 0.75 mm<sup>2</sup> (24 x 0.20 mm) to BS 6500 Table 16.

If a new cable is needed it must be connected into the terminals marked L (Brown or Red lead), N (Blue or Black lead) and  $\frac{1}{2}$  (Green/Yellow or Green) and be held securely in the cable clamp.

For access refer to Section 14. **NOTE:** Ensure the earth lead is longer than the live and neutral leads.

**10.6** The wiring between the appliance and the electrical supply shall comply with current IEE Wiring Regulations and any local regulations which apply.

**10.7** If a room and/or frost thermostat is to be fitted refer to Figs. 10 and 11. The thermostats must be suitable for use on mains voltage.

**10.8** A facia mounted programmer is available as an extra. Instructions are supplied with the programmer kit.

**10.9** A time switch or programmer can be fitted externally to the appliance.

**10.10 SAFETY CHECK.** After installation or in the event of an electrical fault the electrical system shall be checked for short circuits, fuse failure, incorrect polarity of connections, earth continuity and resistance to earth.

**Fig. 7. Wiring Diagram — Control panel and facia.**  
(All components shown viewed from front of appliance.)

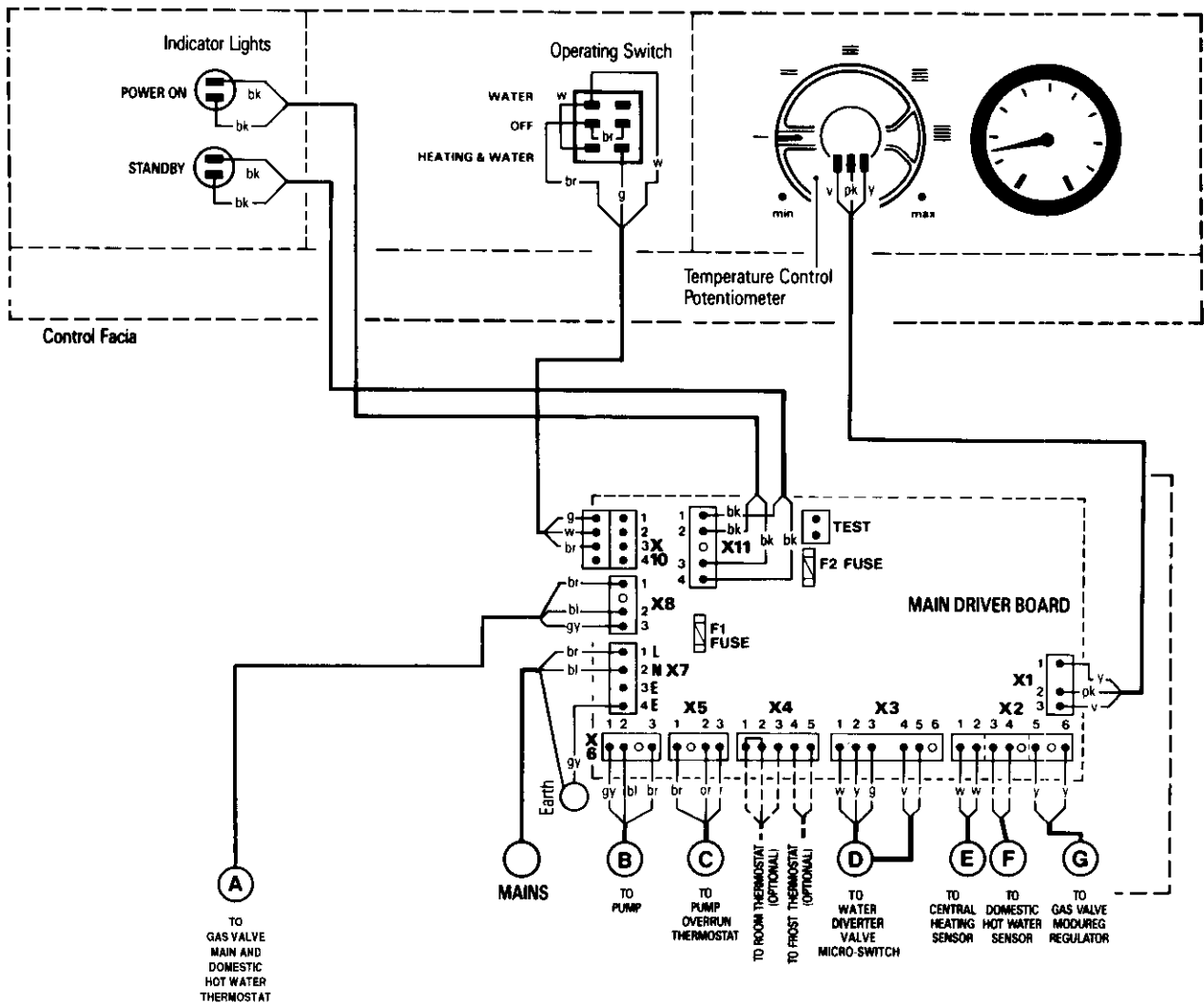

### COLOUR CODE

br—brown bl—blue gy—green and yellow bk—black or—orange  
r—red w—white y—yellow g—grey v—violet pk—pink

**Fig. 8. Wiring Diagram — Components outside control panel.**

(All components shown viewed from front of appliance.)

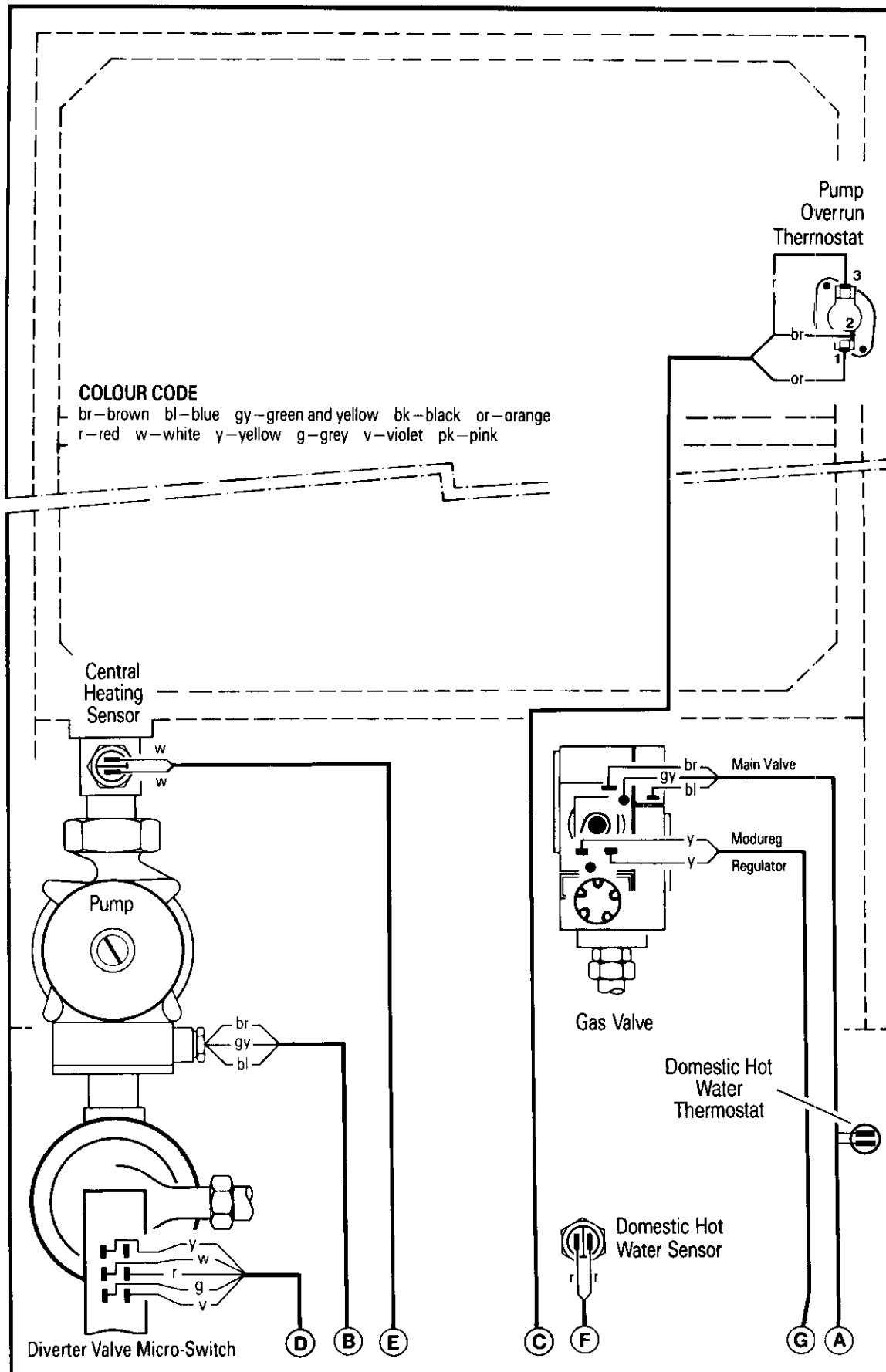

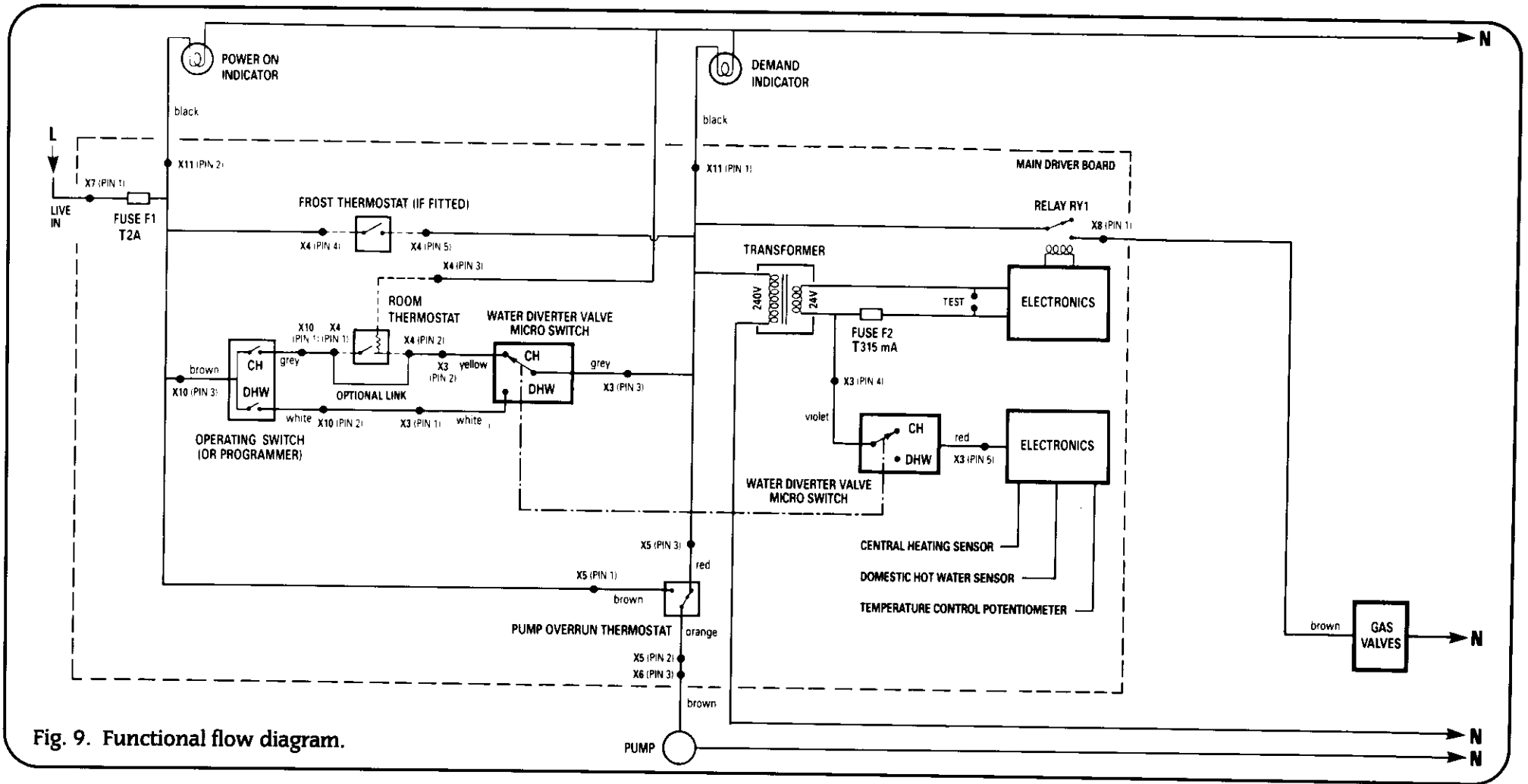

Fig. 9. Functional flow diagram.

Fig. 10. Room thermostat connections.

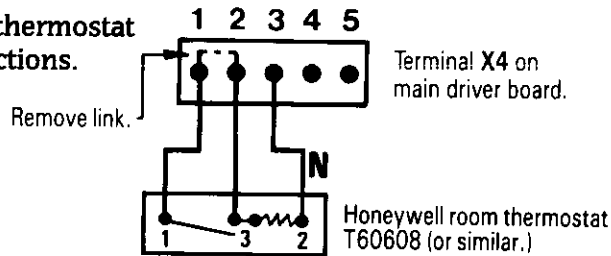
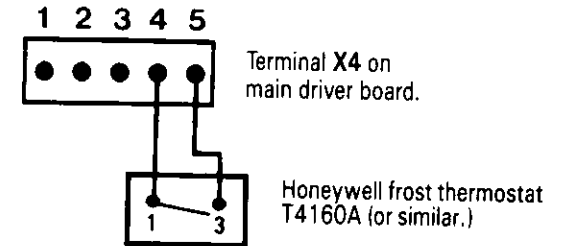

Fig. 11. Frost thermostat connections.



## 11. Installation

11.1 The appliance is supplied suitable for fitting to a sealed system. If it is to be fitted to an open vent system refer to Section 11.2 following and Section 8.

The flue must be installed as specified in BS 5440 Part 1.

**Note: READ THIS SECTION FULLY BEFORE COMMENCING INSTALLATION**

### 11.2 GENERAL FITTING.

Check that the appliance carton contains:- Appliance Installers Instruction Pack Appliance Mounting Plate Users Information Pack Installer Hardware Pack

Check that the position chosen for the appliance is in accordance with the instructions given in Sections 4 and 5.

The distance from the bottom of the mounting plate to the top of the appliance casing is 106 mm.

Hold the appliance mounting plate to the wall. Check that the plate is horizontal. See Fig. 12.

### Sealed System:

Unscrew and discard the automatic air vent cap. See Fig 13.

### Open Vent System:

Remove and discard the automatic air vent. Fit the preformed pipe (optional extra). Connect the feed and expansion tank. See Fig 14.

Connect the flue pipe to the appliance and seal the gap between the pipe and the spigot. The flue must be supported so that its weight is not put upon the appliance. Connect and make good the flue system and terminal as specified in BS 5440:1.

### 11.3 FINAL INSTALLATION

Check that all the water connections and the gas connection have been tightened.

If a fascia mounted programmer is to be fitted, unscrew the upper two screws holding the fascia panel in place and carefully lower the fascia. See Fig. 15.

Unplug the Operating Switch from the terminal **X10** on the main driver board. See Fig. 7. Unscrew the four screws holding the switch plate and remove the complete Operating Switch assembly. Fit the programmer and tighten the four screws. Plug the

Fig. 12. Appliance mounting plate and flue position.

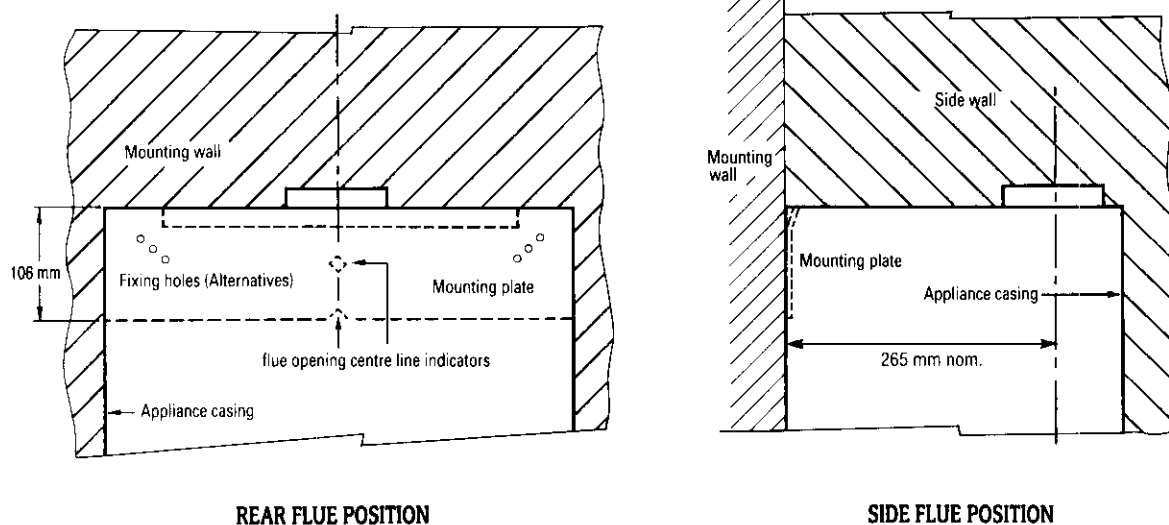

Mark the position of the fixing holes and the position of the flue hole centre line onto the wall.

Drill the fixing holes 60 mm deep for No. 12 size plugs and fix the appliance mounting plate, and check that it is horizontal before tightening the screws.

The gas and water pipes can be led towards the appliance at this stage. See Fig 3. It is recommended that temporary connections be made to thoroughly flush the central heating system. Also flush the primary cold water supply pipe before the appliance is fitted to the wall.

Prepare the opening in the wall or ceiling for the flue pipe. Hang the appliance onto the wall. Drill (at a slight rising angle) through the two appliance fixing holes at the bottom of the casing. Plug and fix the casing bottom. Connect the gas, water and pressure relief valve connections to the appliance. A 15 mm shut-off valve (supplied with the Installer Pack) must be fitted to the cold water supply connection. See Fig 3.

Remove the cabinet front panel. Refer to Section 14.3 (a).

programmer into terminal **X10** on the main driver board.

Lower the control box as described in Section 14.3(d).

Connect the mains electrical supply to the appliance and connect any room and/or frost thermostats. The electrical leads to the room and frost thermostats must pass through the appropriate holes in the control panel and be fixed with the cable clamps provided. See Fig. 16. Refit the control box and fascia panel.

Test the gas supply pipework up to the appliance for soundness as indicated in BS 6891.

Refer to Section 12 for a full description of the filling, venting and, with a sealed system, the pressurising of the system.

If the appliance is not to be commissioned immediately, replace the cabinet front panel. Check that the gas supply, the electrical supply and the water connections are all turned off.

If the premises are to be left unoccupied during frosty conditions, then commission the appliance as described in Section 12 and leave it under the control of the frost thermostat or leave operating continuously with the room thermostat set at 6°C.

If the unoccupation is to be of a long duration then drain the appliance and system and commission the appliance upon re-occupation.

**Fig. 13. Automatic air vent.**

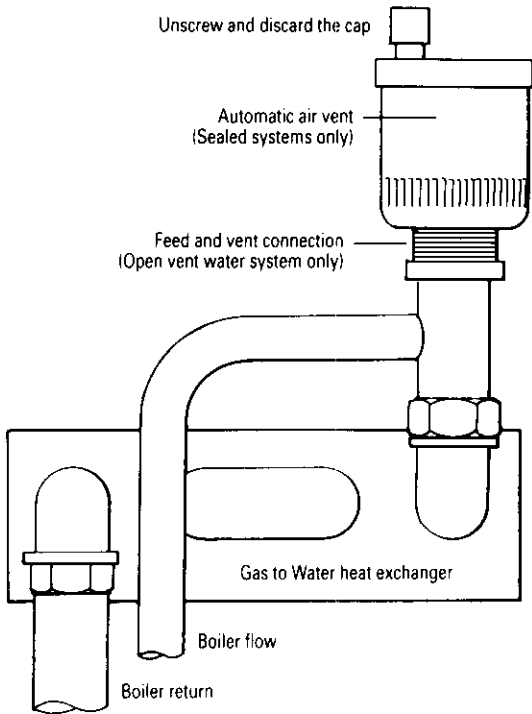

**Fig. 14. Pipe connection for open vent systems.**

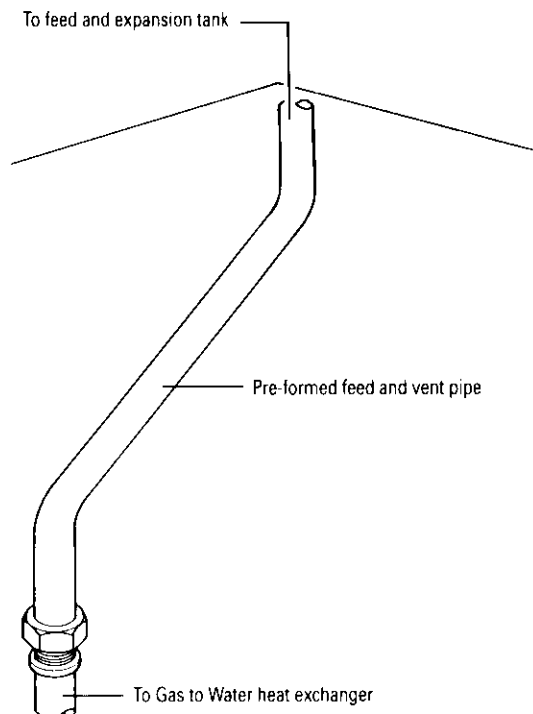

**Fig. 15. Appliance casing and control equipment fixings.**

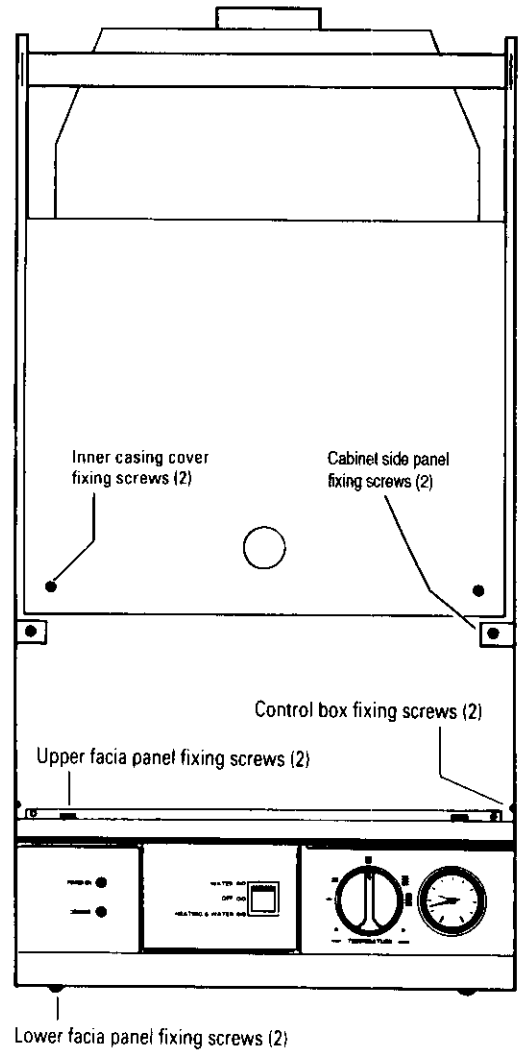
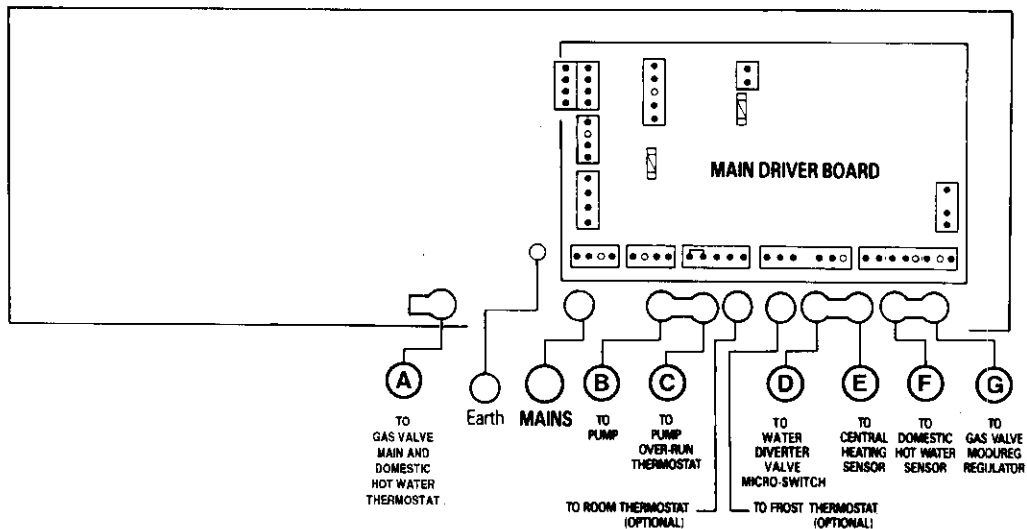

Fig. 16. Electrical cable exits from control box.



## 12. Commissioning

**12.1** The appliance is despatched with the controls set to provide a maximum output for domestic hot water of 24 kW (82,000 Btu/h) and satisfy a central heating load of 16.1 kW (54,900 Btu/h).

**Domestic Hot Water System.** Check that the mains water supply has been fully flushed out at installation.

**Central Heating System.** Check that the central heating system has been fully flushed out at installation.

**Gas Service.** The complete system, including the meter, must be inspected and tested for soundness and purged as indicated in BS 6891.

### 12.2 APPLIANCE AND CENTRAL HEATING SYSTEM PREPARATION

Remove the cabinet front panel.

Check that the electrical supply and the gas service to the appliance are off. See Fig 3.

Check that all the water connections throughout the system are tight.

Open the system valves at the appliance. See Fig 3. Open all the radiator valves, fill the system and vent each radiator in turn.

On sealed systems the automatic air vent, (fixed to the flow manifold) will vent the appliance. Check that the air vent cap has been removed. See Figs 13.

Check that the pressure relief valve operates by turning the knob anti-clockwise until it releases. Water should be expelled from the discharge pipe. See Fig. 17. Lower the control box to gain access. Refer to Section 14.3(d).

#### SEALED SYSTEMS ONLY

##### Set the Expansion Vessel Pressure

The charge pressure of the expansion vessel as despatched is 0.5 bar, which is equivalent to a static head of 5 metres (17 ft). The charge pressure must not be less than the static head at the point of connection. See Fig. 4. A Schraider type tyre valve is fitted to the expansion vessel to allow the charge pressure to be increased if necessary.

##### Set the System Pressure

Fill the system until the pressure gauge shows 2.5 bar (37 lb/ins<sup>2</sup>) and check for water soundness. Release water from the system using the relief valve test knob until the System Design

Pressure is obtained, up to a maximum of 1.5 bar.

System Design Pressure in bar = Static Head of the System in bar + 0.3

**Note:** 1 bar is equivalent to 10.2 metres (33.5 ft) of water.

Set the movable pointer on the pressure gauge to coincide with the indicating pointer giving a permanent record of the set system pressure.

If the pressure indicated on the pressure gauge is greater than 2.5 bar when operating at the maximum central heating temperature, an extra expansion vessel must be fitted to the system as close as possible to the appliance central heating return connection.

The appliance (as despatched) can accommodate a system volume of about 104 litres. Refer to BS 7074 Part 1. If the system volume is in excess of that accommodated by the expansion vessel fitted to the appliance then an extra vessel must be fitted as close as possible to the central heating return connection of the appliance.

Any extra vessel fitted must be pressurised to the same figure as the integral vessel. If the expansion vessel fails then the specified replacement must be fitted.

### 12.3 PROGRAMMER

Any programmer fitted on the appliance should be set up at this stage following the instructions sent with the programmer. The

Fig. 17. Pressure relief valve.

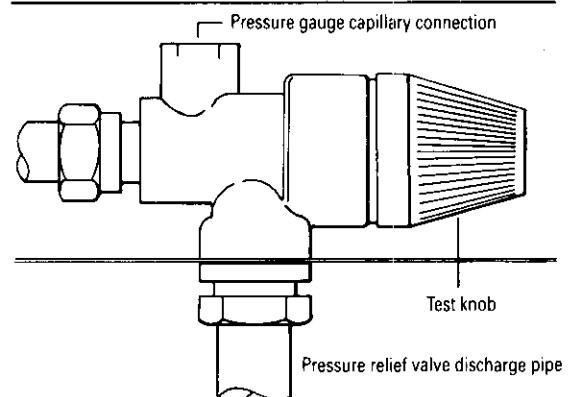

plug-in programmer will retain the setting for up to four weeks following an interruption in the electricity supply.

#### 12.4 APPLIANCE OPERATION

Check that the gas supply to the appliance is off. Switch the electricity supply on at the mains. Put the Operating Switch to Heating and Water. Leave the system to operate in a cold state for about 20 minutes, venting as necessary to remove air from the system.

Set the Operating Switch to OFF. Switch off the electrical supply to the appliance. Turn on the gas supply. Check for gas soundness around the gas valve.

Light the pilot by pressing in the grey button on the gas valve and operating the red spark igniter button. When the pilot has lit continue to hold the grey button in for a further 20 seconds and then release it slowly.

If the pilot does not stay alight, twist the gas valve button anti-clockwise. Wait for 3 minutes and repeat the operation until the pilot has lit. Continue to hold the gas valve button for 30 seconds then release it slowly.

Test for gas soundness at the joint between the pilot pipe and the burner with leak detection fluid.

Observe the pilot flame. It should be about 18-20 mm long and envelope the thermocouple tip. If not, refer to Section 14.4. See Fig. 23.

Loosen the burner pressure test point screw and connect a pressure gauge. See Fig. 18.

##### Domestic Hot Water.

Set the Operating Switch (or Programmer) to **WATER** and fully open a hot water tap.

The boiler should light at a burner pressure of 2.3 mbar (0.8-1.2 in. wg.) rising immediately to 14 and 14.5 mbar (5.6 and 5.8 in. wg.). If the burner pressure is low, check that the supply pressure at the gas valve inlet with the appliance operating is at least 19 mbar (7.6 in. wg.).

**Note:** The burner pressure is factory set and if (after checking that the supply pressure is sufficient) the correct pressure is not obtained then Worcester Heat Systems Service Department should be contacted.

With the main burner alight test the integral gas supplies and joints for soundness using leak detection fluid.

Gradually close the hot tap and check that the burner pressure drops. Fully open the tap and check that the burner pressure rises. After 10 minutes operation check for spillage at the diverter outlet as described in BS 5440:1. Fully close the tap and check that the burner goes off. The pump will continue running until the appliance has cooled to a preset temperature.

Set the Operating Switch (or Programmer) to **OFF**.

##### Central Heating

Check that all the radiator valves are open. Set the room thermostat and the Central Heating Temperature Control to maximum.

On sealed systems check that the system is pressurised and set to the required pressure as indicated on the gauge.

Set the Operating Switch (or Programmer) to **HEATING & WATER**.

The burner will light.

The appliance will modulate its output from 9.2 kW (31,400 Btu/h) to the set output of 16.1 kW (54,900 Btu/h) over a period of about two minutes.

Check the system to ensure that all the radiators are heating up evenly.

Shut down all but one of the radiators and observe the burner pressure fall. Open all of the radiator valves and check that the burner pressure rises.

If a greater heat output up to a maximum of 24 kW (82,000 Btu/h) is required, then the burner pressure must be adjusted at the potentiometer located at the rear of the control box. Adjust the potentiometer to give a burner pressure of 14.5 mbar. This

figure can only be achieved if the burner pressures are correctly set in the domestic hot water mode.

Balance the system so that the required temperature difference across the central heating flow and return pipes is obtained. See Table 3.

Adjust the central heating by-pass valve until the same temperature difference is obtained. See Fig 19. This should be carried out with only a single radiator operating. If thermostatic radiator valves are fitted then one radiator should be left uncontrolled. The bypass valve should never be fully closed.

Set the room thermostat to minimum and check that the burner goes out. Reset the room thermostat to maximum and the burner will relight and follow the normal operating procedure.

Set the Operating Switch (or Programmer) to **OFF**.

Turn off the gas service cock and the electrical supply to the appliance. After about 60 seconds the flame failure device can be heard to operate. Check for its correct operation by turning the gas back on at the gas cock and attempting to light the pilot without depressing the gas valve button. If the pilot can be lit in this way, turn off the gas supply and contact Worcester Heat Systems.

Disconnect the pressure gauge and re-tighten the test point screw. Test for gas soundness at the screw.

Drain the system while the appliance is still hot.

Refill, vent and, with a sealed system, re-pressurise as described in Section 12.2.

##### Domestic Hot Water and Central Heating

Light the pilot as described in the preceding notes.

Set the Operating Switch (or Programmer) to **HEATING & WATER**. If a programmer is fitted, set the domestic hot water to **Continuous** or **24Hrs** and the central heating to **ON**. The burner will light and heat will pass into the system. Turn on a hot water tap and check that fully heated hot water is discharged from the tap.

Close the tap and the burner will go off. The appliance will then return to the central heating mode and automatically balance with the system requirements.

Set the Operating Switch (or Programmer) to **OFF** and the burner will go out.

#### 12.5 COMPLETION OF COMMISSIONING

Disconnect the pressure gauge and tighten the test point screw.

Restart the appliance and check for gas soundness around the test point screw.

Refit the cabinet front panel.

If the appliance is being passed over to the user immediately, refer to Section 13 – Instructions to the User and set the controls to the user's requirements.

If the appliance is to be left inoperative, check that the Operating Switch is set to **OFF**. Turn off the gas service cock and switch off the electricity supply.

If there is any possibility of the appliance and system being left inoperative during frosty conditions, drain the appliance and system. For short inoperative periods leave the boiler under the control of a frost thermostat or operating continuously under the control of a room thermostat set at 6°C.

## 13. Instructions To The User

**13.1** Tell the user how to operate the appliance and hand over the Users Instructions leaflet.

**13.2** Tell the user what to do if the the heating system is not to be used in frosty weather.

**13.3** Tell the user the sealed system set pressure if applicable.

**13.4** Tell the user of the importance of regular servicing. Worcester Heat Systems Ltd offer a comprehensive maintenance contract.



Fig. 18. Gas valve.

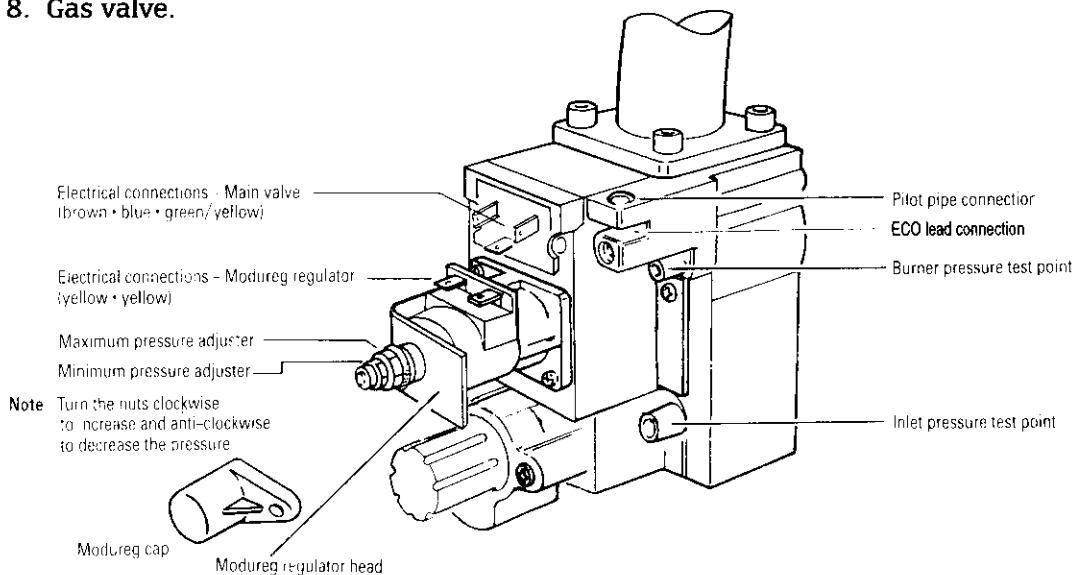
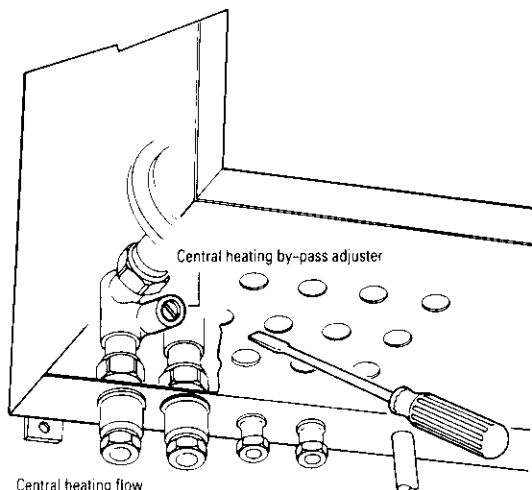

Fig. 19. Central heating by-pass adjuster.



13.5 Set the system controls to the user's requirements.

13.6 If an external programmer has been fitted which has a programmable domestic hot water facility then it is suggested that this be set to **Continuous** or the equivalent.

## 14. Inspection and Servicing

14.1 To ensure continued efficient operation of the appliance it must be checked and serviced as necessary at regular intervals. The frequency of servicing will depend upon the particular installation conditions and usage, but once per year should generally be adequate. The extent of the service required by the appliance is determined by the operating condition of the appliance when tested by fully qualified engineers.

Any service work must be carried out by competent engineers such as British Gas or Corgi registered personnel.

### 14.2 PRE-SERVICE INSPECTION

Check that the flue terminal is clear.

Check that the ventilation and combustion air openings are clear. See Section 6 – Air Supply.

Check the system and remake any joints or fittings which show signs of leakage.

Refill, vent and, with a sealed system, re-pressurise as described in Section 12. 2.

Operate the appliance and the system taking note of any faults.

### Warning

Disconnect the electrical supply at the mains and turn off the gas supply at the gas service cock on the appliance before servicing. See Fig. 3.

After completing the service always test for gas soundness as indicated in BS 6891.

### 14.3 DISMANTLE THE APPLIANCE

To carry out a full and comprehensive service of the appliance remove the following parts to gain access to the components which need to be checked or serviced.

(a) **Cabinet Panels.** Remove the front panel by lifting off the supports. Lower the control box as described in Section 14.3(d). Pull off the lead from the spark generator. Unscrew the screw fixing each of the cabinet side panels and remove the panels. See Fig. 15.

(b) **Inner Casing Cover.** Remove the cabinet front panel. Unscrew the two screws securing the cover to the casing and remove. See Fig 15.

(c) **Facia Panel.** Check that the electricity supply to the appliance is turned off. Remove the cabinet front panel. Unscrew the two screws and lower the facia assembly. See Fig. 15.

(d) **Control Box.** Remove the cabinet front panel. Unscrew the two screws as shown in Fig. 15. Support the assembly and allow it to hinge down into the servicing position.

(e) **Diverter.** It is not necessary, nor possible to remove the diverter assembly when servicing the appliance.

(f) **Combustion Chamber Cover.** Remove the the inner casing cover. Unscrew the four screws securing the cover and pull downwards to remove the cover. See Fig 20.

(g) **Main Burner Assembly.** Remove the combustion chamber cover. Unscrew the pilot fixing screws. Unscrew the two screws and remove the burner assembly by lifting the front of the burner and pulling forward. See Fig. 22.

(h) **Flue Clean-Out Cover.** Unscrew the four screws and remove the cover.

(i) **Thermostat Cover.** Unscrew the two screws and move the cover to one side (electrical leads still attached). See Fig. 20.

### 14.4 SERVICE OF COMPONENTS

**Clean the Main Burner.** Brush the blade tops and mixing tube with a soft non-metallic brush and check that all the flame ports are clear. Inspect the injector and clean with a soft brush. Replace the injector if it appears damaged. Do not use a wire

Fig. 20. Appliance components and fixings (upper assembly).

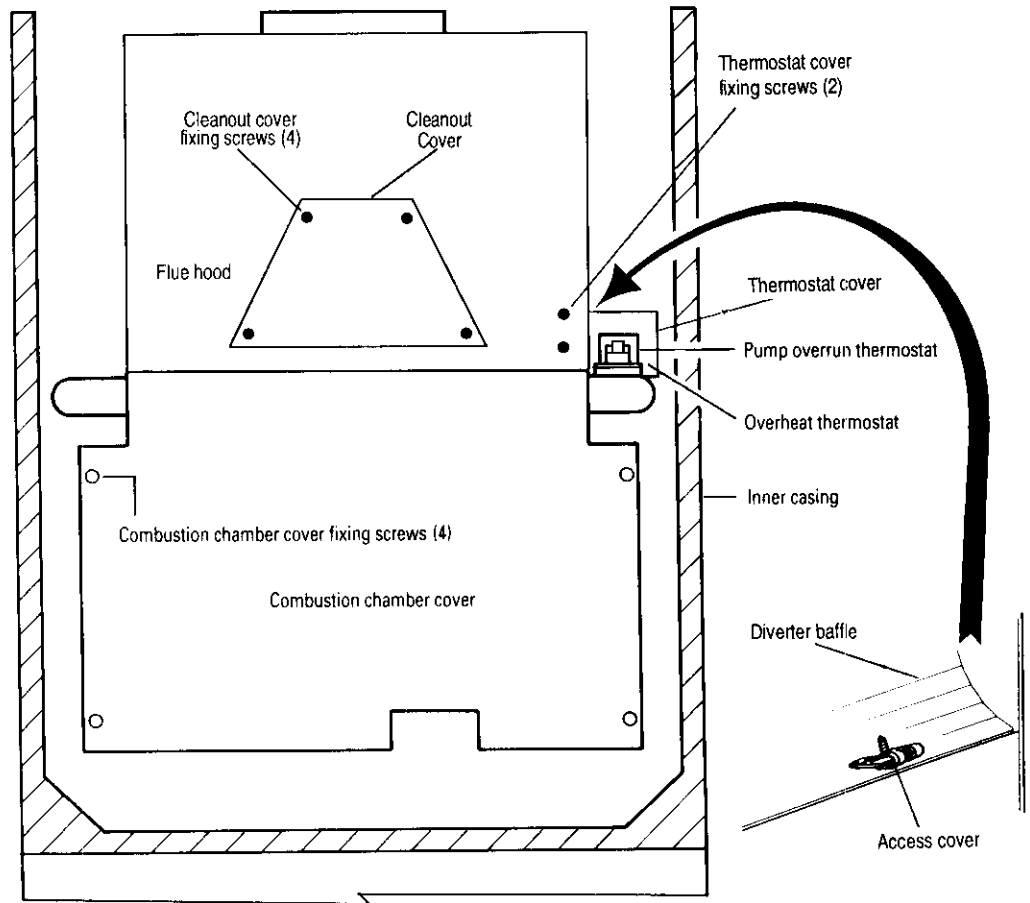
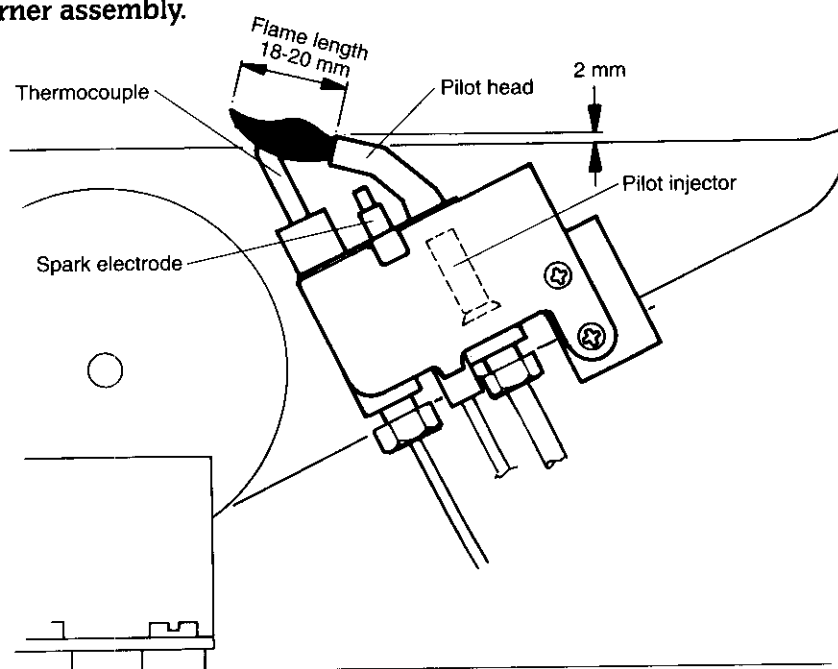

Fig. 21. Pilot burner assembly.



brush or anything likely to cause damage.

The burner is fitted with a lint filter which can be removed by unscrewing the nut at the end of the burner and removing the endcap. Brush or wash in soapy water and carefully refit. Check that the endcap is fitted correctly before tightening the nut.

**Clean the Pilot Burner Assembly.** Brush with a soft brush. Remove the pilot injector and clean by rinsing it in warm water. Replace the thermocouple if it appears damaged. Replace the spark electrode if it appears damaged. Fit the electrode lead before replacing the electrode.

**Clean the Gas to Water Heat Exchanger.** Cover the main burner manifold with a cloth. Clean the heat exchanger using a soft brush. Remove the deposits from the bottom of the combustion

Before removing any component holding water it is important that as much water as possible is removed from the appliance.

**(a) Appliance.** Turn off the central heating flow and return valves at the appliance. See Fig 3. Fit a tube to the drain tap on the Water to Water heat exchanger and open the tap about one turn. See Fig 26. Close the drain tap when the flow has stopped. Extra water can be removed by operating the relief valve knob. **Some water will remain in the expansion vessel, pump, diverter valve and Gas to Water heat exchanger and extra care must be taken when removing these components.**

**(b) Domestic Hot Water Circuit.** Turn off the mains cold supply valve at the appliance using a flat-bladed screwdriver and open the lowest hot water tap. See Fig 3. **A quantity of water will**

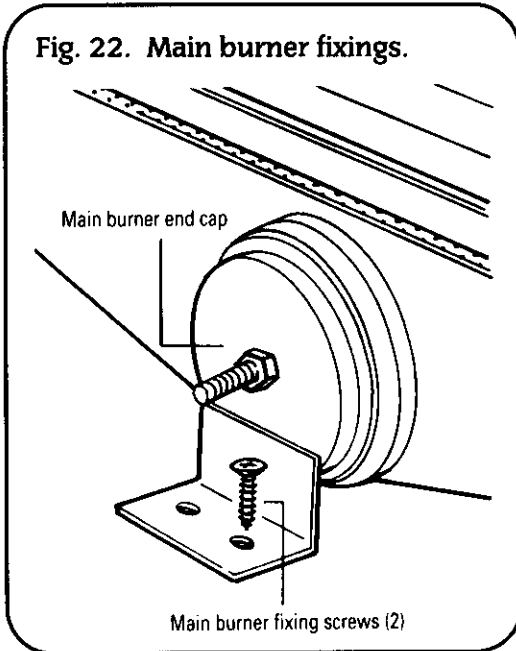

Fig. 22. Main burner fixings.

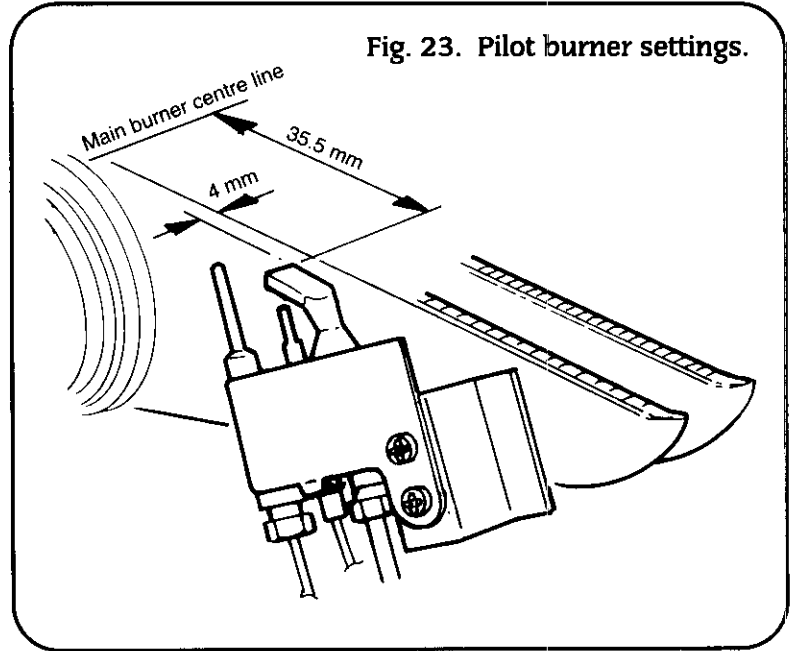

Fig. 23. Pilot burner settings.

chamber. Do not distort any of the blades.

**Combustion Chamber Insulation.** Examine and replace any pads that are damaged. See Section 15.7.

**Controls.** Remove any dust or deposits using a soft non-metallic brush. Take care not to mishandle any component connections.

Reassemble the appliance in the reverse order.

Check that ALL components are in place and correctly fixed. Leave the cabinet front panel to be fitted after checking the operation of the appliance.

#### 14.5 TEST THE APPLIANCE

On completion of the service and reassembly of the appliance, check for gas soundness and the correct operation of the appliance as described in Section 12 – Commissioning.

Refit the cabinet front panel and reset the controls to the users requirements.

## 15. Replacement of Parts

### 15.1 WARNING.

Switch off the electricity and gas supplies before replacing any components. After the replacement of any components, check for gas soundness where relevant and carry out functional checks as described in Section 12 – Commissioning

### 15.2 COMPONENT ACCESS

To replace components it is necessary to remove one or more sections of the cabinet and cover plates within the appliance as described in Section 14.3. The fascia panel and control box may also need to be lowered as described in Section 14.3

### 15.3 DRAINING THE APPLIANCE

Check that the electricity supply to the appliance is turned off.

**remain in the Water to Water heat exchanger and the diverter valve and extra care must be taken when removing these components.**

### 15.4 COMPONENT REPLACEMENT

**1. Automatic Air Vent.** (Sealed system installation only.) See Fig 13.

Remove the cabinet front panel and left-hand side panel as described in Section 14.3(a).

Drain the appliance as described in Section 15.3(a).

Unscrew the assembly. Take care not to distort the pipework.

Fit the replacement assembly.

Open the valves and fill and re-pressurise the system as described in Section 12.2.

**2. Overheat Thermostat** See Fig 20.

Check that the electricity supply to the appliance is turned off.

Remove the cabinet front panel, the right-hand side panel and the thermostat cover as described in Section 14.3(a) and (i).

Unscrew the two screws to release the thermostat head. Release the thermostat connections at the gas valve. See Fig. 8.

Fit the replacement thermostat in reverse order ensuring that some heat sink compound is on the mounting plate.

**3. Gas to Water Heat Exchanger.** See Figs 13, 24 and 25.

Check that the electricity supply to the appliance is turned off.

Remove the combustion chamber cover as described in Section 14.3(f).

Drain the appliance as described in Section 15.3(a).

Remove the screw securing the control box at the left-hand side and lift off the left-hand side panel.

Remove the pump overrun thermostat, overheat thermostat, and main burner as described in Sections 14.3(g), 15.4.6 and 15.4.2.

Remove the side panels of the combustion chamber by carefully removing the insulation and removing the four screws. See Fig. 25.

Unscrew the flow pipe at the heat exchanger and at the bottom left of the inner casing and remove the pipe.

Unscrew the return connection at the bottom left of the inner casing and manoeuvre the heat exchanger from the casing.

Transfer the return pipe to the new heat exchanger.

Fit the replacement heat exchanger in the reverse order ensuring all the fibre washers are in place and a layer of heat sink compound is on each thermostat pad. Align the return pipe and tighten the connection. Refit the combustion chamber side plates and insulation pads.

Re-assemble the appliance in the reverse order.

Open the valves and fill and re-pressurise the system as described in Section 12.2.

#### 4. Pump Overrun Thermostat. See Figs 8 and 20.

Check that the electricity supply to the appliance is turned off.

Remove the cabinet front panel, right-hand side panel and thermostat cover as described in Section 14.3(a) and (i).

Unscrew and loosen the access cover on the baffle. See Fig. 20.

Use a long screwdriver, from above, to loosen the rear M4 screw securing the thermostat to its mounting place on the Gas to Water heat exchanger. Remove the front screw and thermostat.

Carefully remove the three wires from their connections and make note of their positions.

Fit the leads to the new thermostat.

Fit the replacement thermostat ensuring a layer of heat sink compound is between the faces.

#### 5. Combustion Chamber Insulation. See Fig 25.

Check that the electricity supply to the appliance is turned off.

Remove the combustion chamber cover as described in Section 14.3(f). Remove the fibre insulation pads from the combustion chamber side, rear, and front.

Fit the replacement pads in the reverse order taking care not to damage them.

#### 6. Main Burner. See Fig. 22.

Check that the electricity supply to the appliance is turned off.

Remove the burner assembly as described in Section 14.3(g).

Fit the replacement burner in the reverse order taking care not to bend the pilot bracket on the main burner.

#### 7. Thermocouple. See Figs. 21, 26.

Remove the inner casing cover as described in 14.3(b).

Unscrew the two screws and remove the pilot burner from the main burner.

Unscrew the thermocouple at the pilot burner and the gas valve and remove.

Fit the replacement thermocouple in the reverse order and refit the pilot burner.

#### 8. Pilot Burner. See Figs. 21 and 23.

Remove the inner casing cover as described in 14.3(b).

Unscrew the two screws and remove the pilot burner from the main burner. Undo the pilot pipe. Unscrew and remove the thermocouple.

Remove the spark electrode cable and pull out the electrode.

Fit the replacement burner in the reverse order ensuring that the pilot injector is in place. Fit the electrode lead before replacing the electrode. Check the pilot burner settings as shown in Fig. 23.

#### 9. Main Burner Injector. See Fig. 22

Remove the main burner as described in Section 15.4.6.

Unscrew the brass injector at the back of the combustion chamber.

Fit the replacement injector in the reverse order.

#### 10. Spark Electrode. See Figs. 21 and 23

Check that the electricity supply to the appliance is turned off.

Remove the pilot burner assembly as described in Sections 14.3(b) and 15.7.

Pull the spark electrode out of the clip.

Fit the replacement electrode in the reverse order, checking that the spark gap is 4 to 5 mm. Fit the electrode lead before replacing the electrode.

#### 11. Pilot Burner Injector. See Fig 21

Remove the inner casing cover and pilot burner assembly as described in Sections 14.3(b) and 15.4.8. Remove the injector (a push fit inside the pilot assembly).

Fit the replacement injector in the reverse order.

#### 12. Spark Electrode Lead. See Fig. 21

Check that the electricity supply to the appliance is turned off.

Remove the inner casing cover as described in Section 14.3(b).

Carefully pull the lead from the spark electrode and from the spark generator.

Fit the replacement lead in the reverse order. Loosen the pilot assembly to refit the lead to the electrode.

#### 13. Piezo Spark Generator. See Fig. 26

Remove the cabinet front panel as described in Section 14.3(a).

Pull off the electrode lead. Unscrew the two screws and remove the generator.

Fit the replacement generator in the reverse order.

#### 14. Gas Valve. See Fig. 18.

Check that the electricity and gas supplies to the appliance are turned off.

Hang the control box assembly in the servicing position as described in Section 14.3(d).

Disconnect the pilot pipe. Unscrew and remove the black plastic plugs. Carefully pull off the two yellow wires from their terminals. Disconnect the thermocouple and the overheat thermostat lead at the valve. Remove the eight screws securing the valve to the pipework and remove the valve from the appliance.

Fit the replacement gas valve in the reverse order ensuring the sealing washers are correctly fitted.

Turn on the gas supply and check for soundness.

#### To replace the Modureg head only.

Pull off the electrical connections. Unscrew the two screws securing the Modureg head to the main body and remove.

Fit the new Modureg head (Honeywell 3061) in the reverse order ensuring that the gasket is in the correct position.

#### To set the burner pressure. See Fig. 18.

The minimum and maximum burner pressures must be set after a new gas control has been fitted.

Follow the procedure described in Section 12.4 -- Appliance Operation.

Fig. 24. Gas to Water heat exchanger connections.

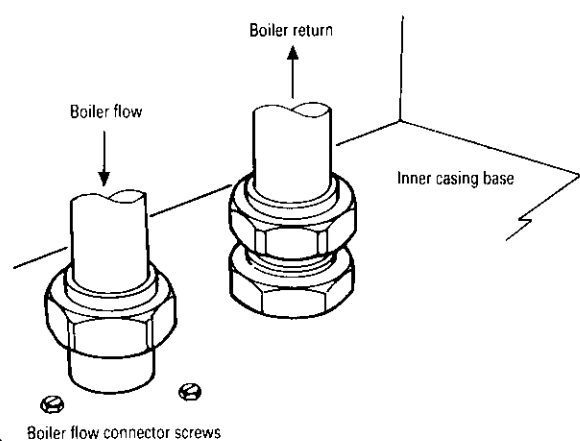

**Fig. 25. Combustion chamber insulation.**

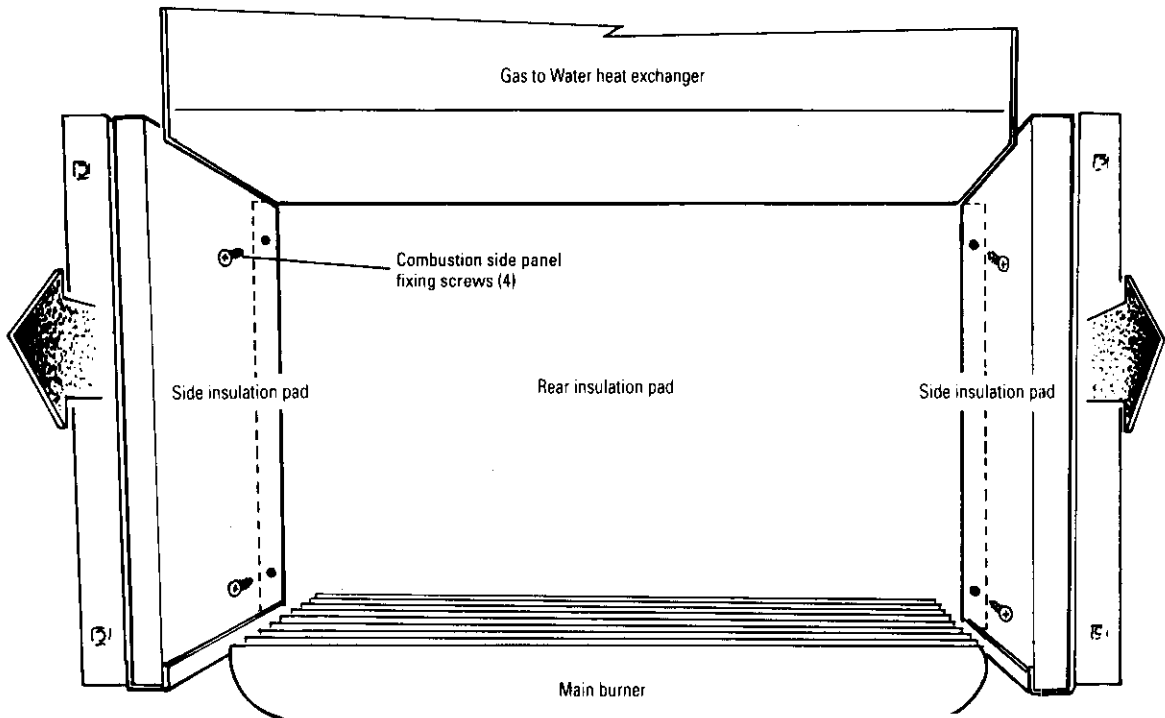

**Fig. 26. Appliance components (lower assembly).**

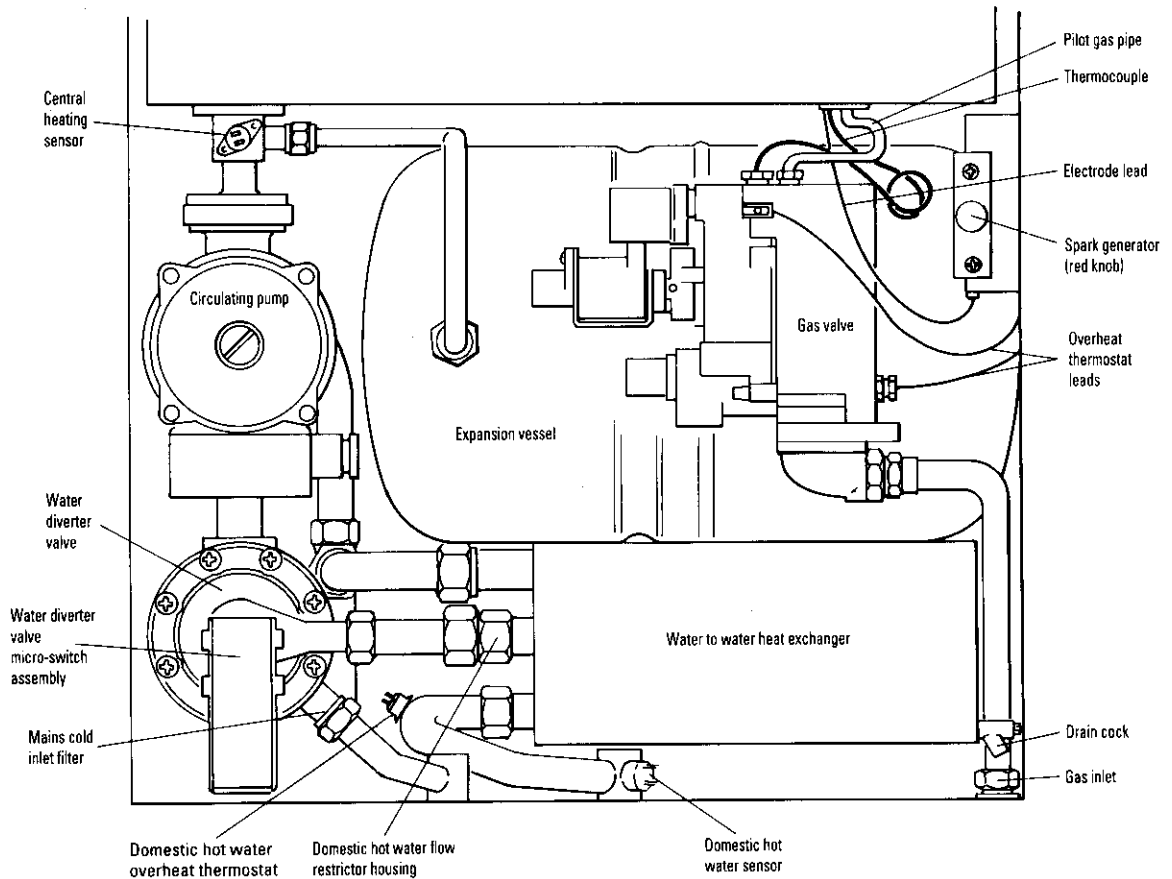

**Fig. 27. Circulating pump.**

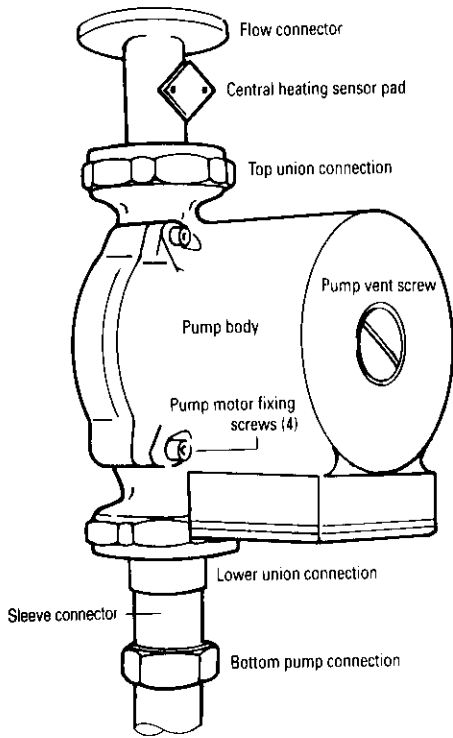

The maximum burner pressure must be set first, as any adjustment of the maximum pressure influences the minimum pressure setting.

Remove the the fixing screw and remove the the Modureg cover.

The Modureg cap must be replaced immediately the adjustments have been made to ensure the proper operation of the gas control.

Start the appliance in the domestic hot water mode as described in Section 12.4 – Appliance Operation.

Adjust the maximum pressure adjustment nut to give a burner pressure of 14.4 mbar. See Fig 18.

Switch off the appliance and turn off the electricity supply. Remove a lead to the Modureg head.

**Fig. 28. Expansion vessel and pump assembly.**

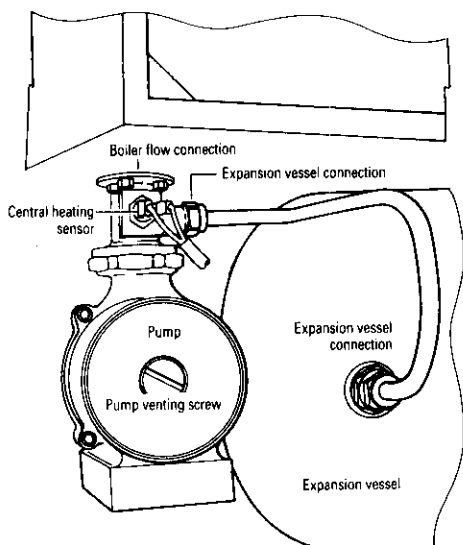

Switch on the electricity supply to the appliance and re-light in the domestic hot water mode. The burner pressure will remain at the minimum setting.

Turn the minimum pressure adjustment screw until the burner pressure is 2.9 mbar. See Fig.18.

Switch off the appliance and turn off the electricity supply. Refit the lead to the Modureg head.

**15. Central Heating Sensor.** See Fig. 26

Check that the electricity supply to the appliance is turned off.

Remove the cabinet front panel as described in Section 14.3(a).

Carefully pull off the two leads from the sensor. Loosen the two M3 screws securing the sensor to the fitting and remove the sensor

Fit the replacement sensor with a layer of heat sink compound between the faces. Refit the leads.

**16. Domestic Hot Water Sensor.** See Fig. 26

Check that the electricity supply to the appliance is turned off.

Hang the control box assembly in the servicing position as described in Section 14.3(d).

Carefully pull off the two leads from the sensor. Loosen the two M3 screws holding the sensor to the fitting and remove the sensor.

Fit the replacement sensor in the reverse order ensuring a layer of heat sink compound is between the faces. Refit the leads.

**17. Circulating Pump.** See Fig 27

Check that the electricity supply to the appliance is turned off.

Drain the appliance as described in Section 15.3(a).

Hang the control box assembly in the servicing position as described in Section 14.3(d).

Undo the two union nuts and remove the pump from the pipework. Support the pump and remove the electrical cover. Disconnect the electrical wires taking note of their positions.

Fit the replacement pump in the reverse order using new sealing washers. Ease back the sleeved connector to allow the fitting of the bottom washer.

Alternatively replace the pump head only by removing the four Allen screws.

Open the valves and fill and re-pressurise the system as described in Section 12.2.

**Note.** The direction of flow should be downwards. The speed should always be set to maximum.

**18. Expansion Vessel.** See Fig 28

Drain the central heating circuit as described in Section 15.3(a).

Hang the control box assembly in the servicing position as described in Section 14.3(d).

Remove the gas valve as described in Section 15.14.

Undo the expansion vessel connection at the boiler flow connection and remove the vessel.

Fit the replacement vessel in the reverse order.

Open the valves and fill and re-pressurise the system as described in Section 12.2.

**19. Pressure Relief Valve.** See Fig 17

Drain the central heating circuit as described in Section 15.3(a).

Lower the control box assembly as described in Section 14.3(d)

Undo the discharge pipe connection and the pressure gauge connection. Unscrew the valve taking care not to distort the pipework.

Fit the replacement valve using a suitable thread sealing compound. Reconnect the discharge pipe and pressure gauge.

Open the valves and fill and re-pressurise the system as described in Section 12.2.

**Fig. 29. Water diverter valve.**

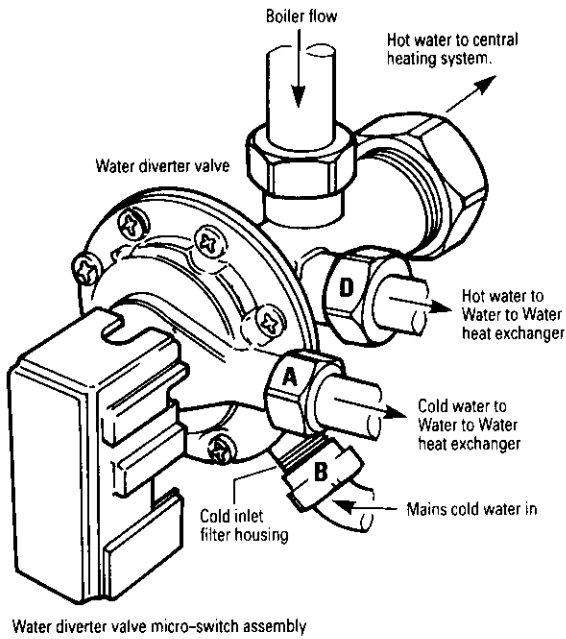

Remove the micro switch assembly as described in Section 15.4.20.

Undo all the water connections to the valve and remove from the appliance.

Fit the replacement valve in the reverse order ensuring that the filter and all fibre washers are in place.

Open the valves and fill and re-pressurise the system as described in Section 12.2.

**22. Water to Water Heat Exchanger.** See Figs. 3, 26, 29 & 30.

Check that the electricity supply to the appliance is turned off.

Drain the appliance and domestic hot water circuits as described in Sections 15.3(a and b).

Loosen the mains cold water inlet connection and locknut at the appliance. See Fig.3.

Hang the control box assembly in the servicing position as described in Section 14.3(d).

Undo connection A and remove the coupling.

Undo connection B and move the pipe to one side. Undo connections C, D and E. Loosen the two screws at the right hand fixing bracket.

**Protect the control box and carefully remove the heat exchanger as some water remains.**

Transfer the boiler flow pipe (removed with the old heat exchanger) to the new heat exchanger using a new fibre washer.

**Fig. 30. Water to Water heat exchanger connections.**

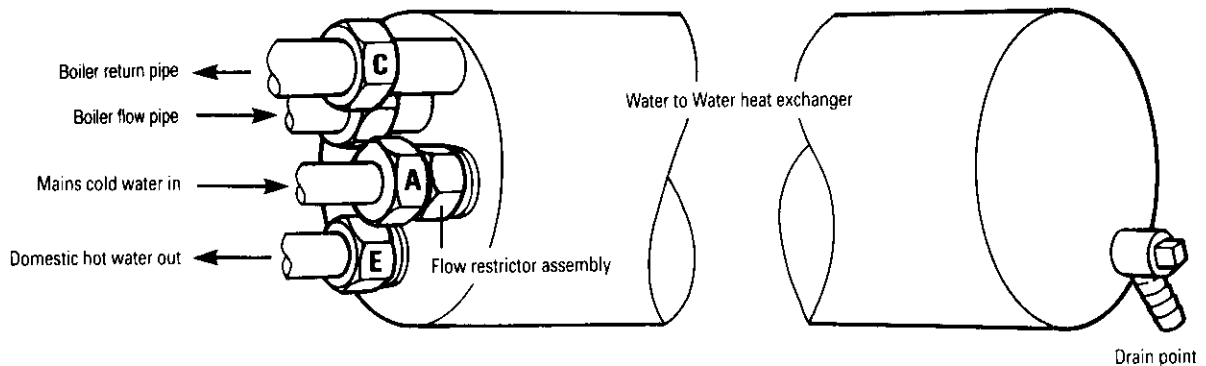

**20. Water Diverting Valve Micro Switch Assembly.** See Fig 29.

Check that the electricity supply to the appliance is turned off.

Lower the control box assembly as described in Section 14.3(d).

Using a pair of fine nosed pliers, pull the circlip off and remove the micro switch assembly from the valve. Lower the fascia as described in Section 14.3(c). Carefully pull off the Molex connection from terminal X3 on the driver board. Remove the strain relief bush to withdraw the switch and lead assembly from the appliance.

Fit the replacement micro switch assembly in the reverse order.

**21. Water Diverting Valve.** See Fig 29

Check that the electricity supply to the appliance is turned off.

Drain the appliance and domestic hot water circuits as described in Sections 15.3(a and b). Hang the control box assembly in the servicing position as described in Section 14.3.(d).

Fit the replacement heat exchanger in the reverse order ensuring all the fibre washers are in place.

Open the valves and fill and re-pressurise the system as described in Section 12.2.

**23. Domestic Hot Water Flow Restrictor.** See Fig 26

Check that the electricity supply to the appliance is turned off.

Drain the domestic hot water circuit as described in Section 15.3(b).

Hang the control box assembly in the servicing position as described in Section 14.3(d).

Undo the water connection A and remove the fitting. The plastic flow restrictor is located within the brass housing on the heat exchanger.

Fit the replacement flow restrictor and reassemble in the reverse order ensuring the fibre washers are in place.

**24. Pressure Gauge.** See Fig 31

Check that the electricity supply to the appliance is turned off.  
Drain the appliance as described in Section 15.3(a). Lower the facia panel as described in Section 14.3(c).

Remove the two screws securing the gauge to the facia panel.  
Hang the control box assembly in the servicing position as described in Section 14.3(d).

Disconnect the capillary at the pressure relief valve and remove the gauge.

Fit the replacement gauge in the reverse order ensuring the fibre washer is in place.

Open the valves and fill and re-pressurise the system as described in Section 12.2.

**25. Operating Switch.** See Fig 31

Check that the electricity supply to the appliance is turned off.  
Lower the facia panel as described in Section 14.3(c).

Remove the leads from the rear of the switch making note of their positions.

Squeeze together the two plastic retaining lugs to remove the switch from the facia.

Snap in the replacement switch and reconnect the leads. Refer to the wiring diagram, Fig. 7

**26. Temperature Control Potentiometer.** See Fig 31

Check that the electricity supply to the appliance is turned off.  
Lower the facia as described in Section 14.3(c).

Pull the knob off the spindle. Unscrew the locknut and remove the potentiometer from the facia panel. Remove the Molex plug from terminal X1 on the driver board.

Fit the replacement potentiometer in the reverse order.

**28. Domestic Hot Water Overheat Thermostat.** See Fig. 26.

Check that the electricity supply to the appliance is turned off.

Hang the control box assembly in the servicing position as described in Section 14.3(d).

Carefully pull off the two leads from the thermostat. Loosen the two M3 screws holding the thermostat to the fitting and remove the thermostat.

Fit the replacement thermostat in the reverse order ensuring a layer of heat sink compound is between the faces. Refit the leads.

**27. Driver Board.** See Fig 7

Check that the electricity supply to the appliance is turned off.

Lower the facia panel as described in Section 14.3(c)

Carefully pull off all the Molex connectors from the board. Disconnect the room and frost thermostat connections (if fitted) from terminal X4. Remove the Operating Switch (or programmer) plug from terminal X10. Disconnect the mains supply leads at terminal X7. Release the plastic catch in each corner of the driver board and pull forward off the control panel.

Fit the replacement board in the reverse order ensuring it is pushed firmly onto the four posts and clicks into place.

Refit the facia panel and hang the control box assembly in the servicing position as described in Section 14.3 (d).

Set the central heating operating pressure to 14.4 mb (5.8 in wg) by adjusting (anti-clockwise to increase the pressure and clockwise to decrease the pressure) the central heating potentiometer accessed through an opening in the rear of the control box. This must be done with the boiler operating in the central heating mode.

The adjustment is made using a thin flat-bladed screwdriver.

**Fig. 31. Facia (rear view in lowered position).**

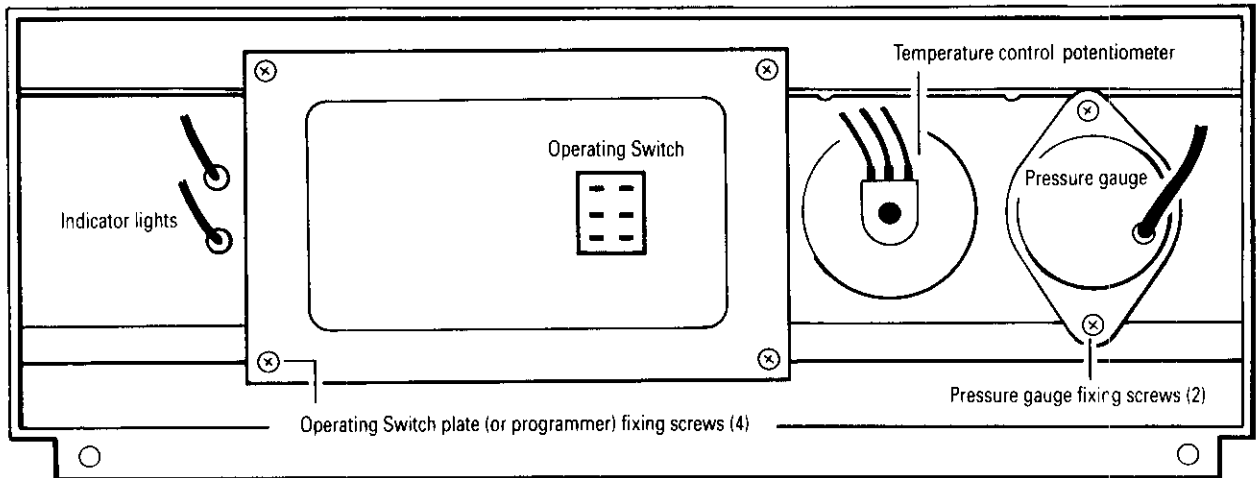



## 16. Short Parts List

Key No.	GC No.	Part	Manufacturer's Reference	No.	WHS Part No.
41	378 581	Gas Valve	Honeywell-V4600N3061	1	ZAGAS181
114	378 585	Modureg Head (Gas Valve)	Honeywell-V7335A3008	1	ZAGAS185
33	378 386	Main Burner	Aeromatic-AC 23/053578	1	ZAGAS164
47	378 387	Lint Arrestor	Aeromatic 600049	1	ZFSPA085
34	379 040	Main Burner Injector	Stereomatic 4.4mm Dia. Type 7	1	ZAGAS163
35	379 673	Pilot Burner	Honeywell-Q385A 2010	1	ZBGAS092
36	382 850	Pilot Burner Injector	Honeywell-45.004, 108-001 38/36A	1	ZBGAS016
37	379 561	Spark Electrode c/w lead	Honeywell 45900413-010	1	ZBGAS078
21	299 150	Gas to Water Heat Exchanger	Giannoni-PR 20/321	1	ZAGAS165
24	379 419	Automatic Air Vent	Intermes-02, 50, 010	1	ZMMIS055
53	299 199	Sensor and paste	Elmwood-6655-9428-4	2	SPK0039
94	299 202	System Pressure Gauge (with Washer)	Cewal	1	SPK0040
74	386 789	Pressure Relief Valve	Caleffi-3141, 3bar	1	ZCVLV018
50	378 034	Circulating Pump	Grundfos-UPS 15-60, 120CL, NOCL 50526613	1	ZAMAJ198
70	378 027	Expansion Vessel (Sealed System)	Inter Albion-MIS082/240	1	ZMMIS082
79	371 537	Water to Water Heat Exchanger		1	SSA6161/1
57	379 216	Diverter Valve	Giannoni-D2040	1	ZAGAS166
97	379 730	Driver Board	Honeywell-W4115B, 1226	1	ZAGAS228
90	386 227	CH Temperature Control Potentiometer	Omeg-OW20BU 10KA	1	SSAHAR002
93	386 778	Operating Switch	Arrow-200400E839AA	1	ZDELE237
10	299 151	Combustion Chamber Insulation (Complete)		1	SPK0033
122	371 539	Programmer Kit (Optional)	WHS Single Channel Grey 490 488	1	ZAMAJ164
42	371 540	Gasket Pack - Gas		1	SPK0022
61	371 541	Gasket Pack - Water		1	SPK0023
60	379 215	DHW Flow Restrictor	Type E, White 8 litres/min. ( $\pm$ 10%)	1	ZBUNC138
91	371 524	Indicator Light - DEMAND	Neon (Green) - complete with plug IMO Ref. N19L R/S-Green	1	SSAHAR081
92	371 525	Indicator Light - POWER ON	Neon (Amber) - complete with plug IMO Ref. N19L R/S-Amber	1	SSAHAR082
22	299 277	Pump Overrun Thermostat plus paste	Thermodisc 60T13-500103	1	SPK0088
59	378 416	Filter	MPMV 3326 Stainless Steel	1	ZBUNC229
115	299 032	Fuse Pack		1	SPK0024
40	390 210	Thermocouple	Honeywell Q309A2747	1	ZBGAS035
48	393 652	Spark Generator	Vernitron 0207	1	ZBGAS010
19	299 152	Overheat Thermostat	Elmwood 2455RC, c/w lead	1	SSAHAR013
7	386 222	Domestic Water Limit Thermostat plus paste	Elmwood 2455R-9082 635	1	SPK0003

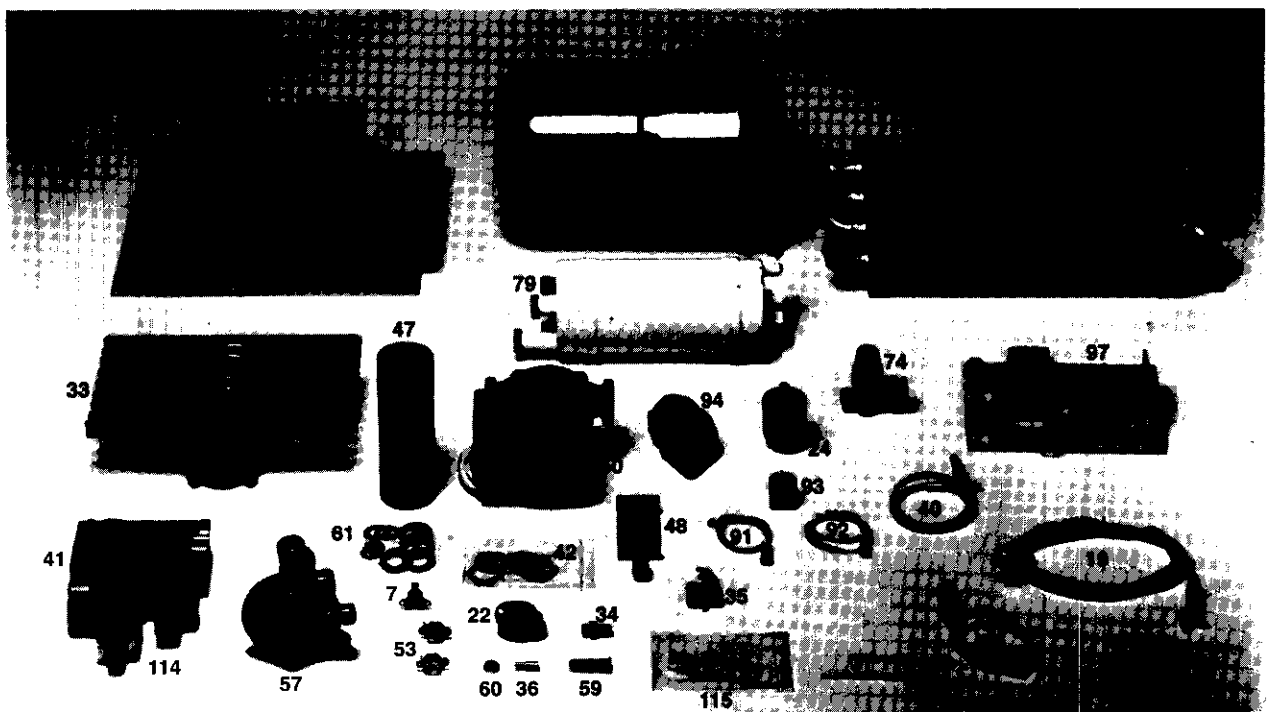

# 17. Operational Flow Diagrams

Note. The alpha references in these charts are to be used for cross-referencing when fault finding. See Section 18.

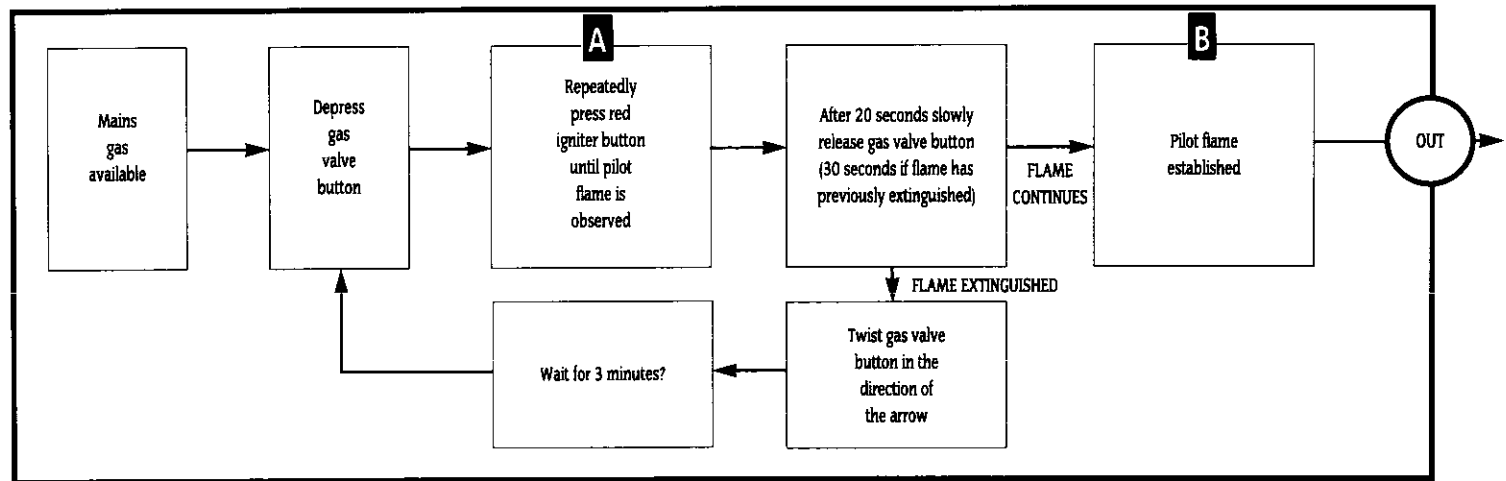
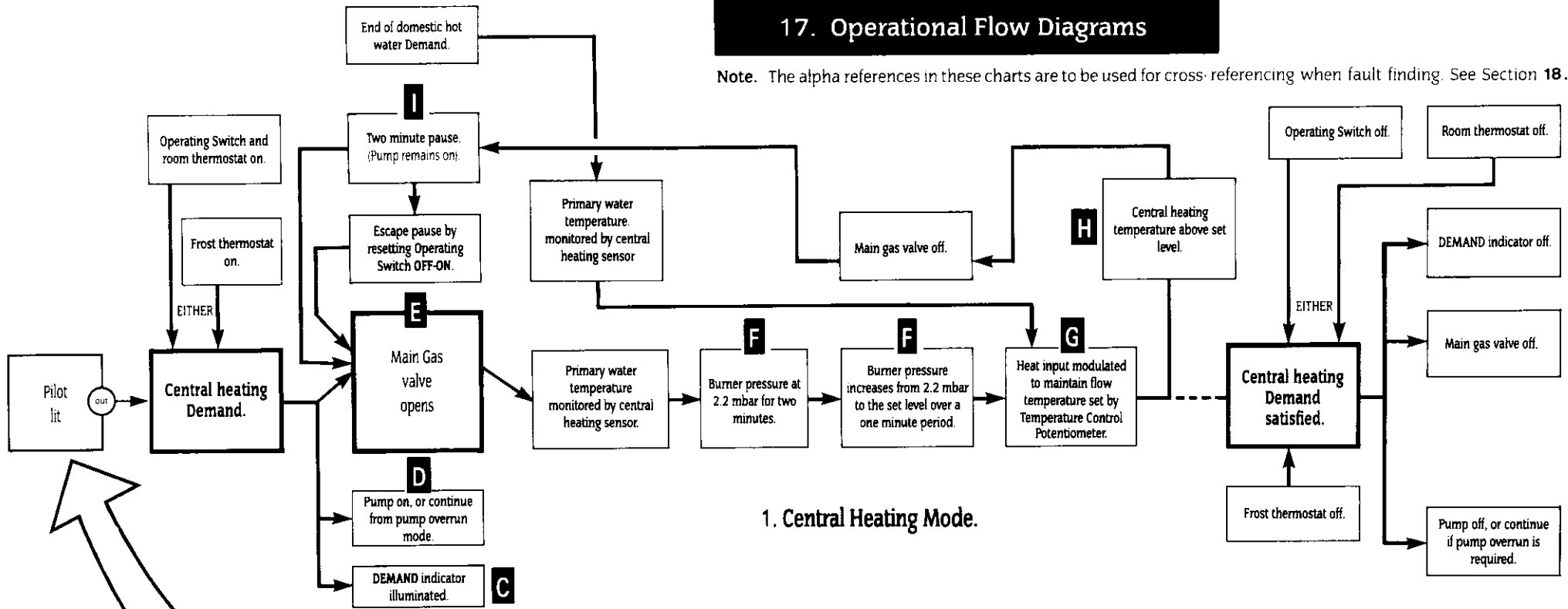

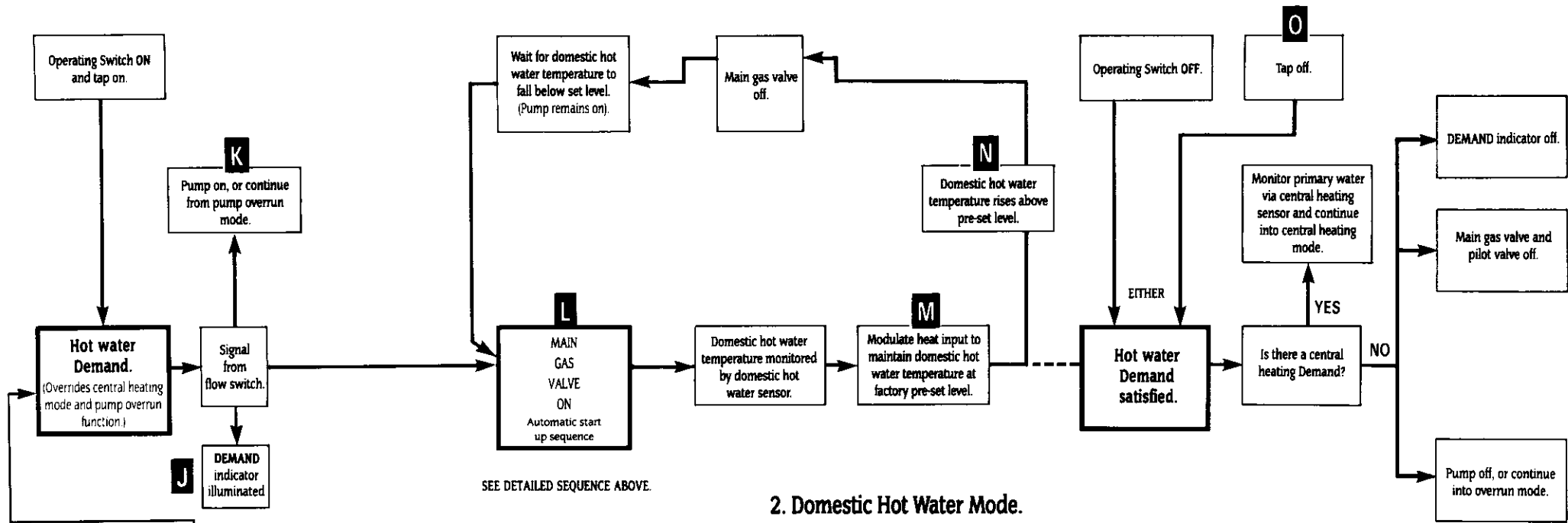

2. Domestic Hot Water Mode.

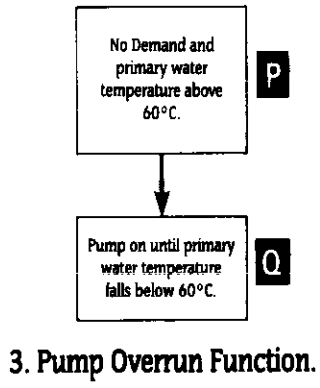
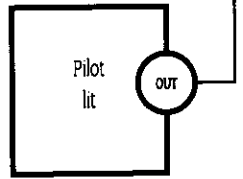

3. Pump Overrun Function.

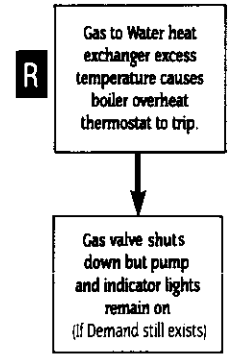

4. Overheat Protection.

# 18. Fault Finding

This Fault Finding Chart is to be used in conjunction with the Operational Flow Diagrams in Section 17. To find the fault, locate the point on the flow diagram at which the appliance has failed, eg, letter B. Then read the corresponding section in the fault finding chart, eg. **Failure at point B.** **Note:** Each section assumes that the appliance operates correctly up to that point.

**Notes.** 1. All voltage measurements are with respect to neutral unless otherwise stated. 2. Before changing any component indicated in the chart, it is essential that the associated wiring is checked for continuity, condition and correct routing. 3. Preliminary electrical system checks are the first electrical checks to be carried out during a fault finding procedure. On completion of the Service/Fault Finding task which has required the breaking and remaking of electrical connections, check—(a), EARTH CONTINUITY, (b), SHORT CIRCUIT CHECK, (c), POLARITY and (d), RESISTANCE TO EARTH.

STANDBY INDICATOR DOES NOT ILLUMINATE

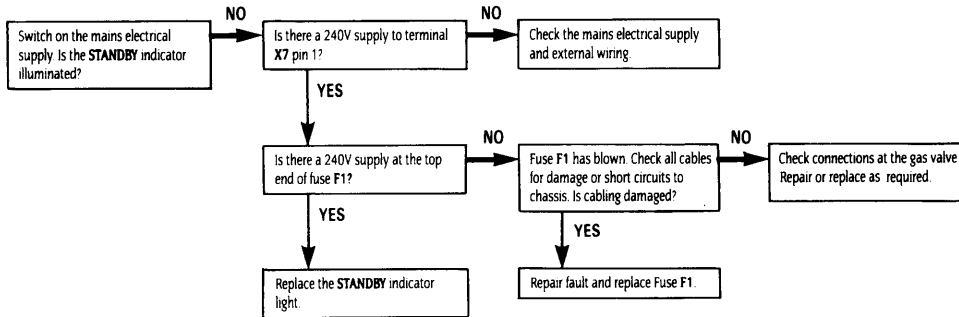

## Start of pilot lighting test

FAILURE AT POINT A

FAILURE AT POINT B

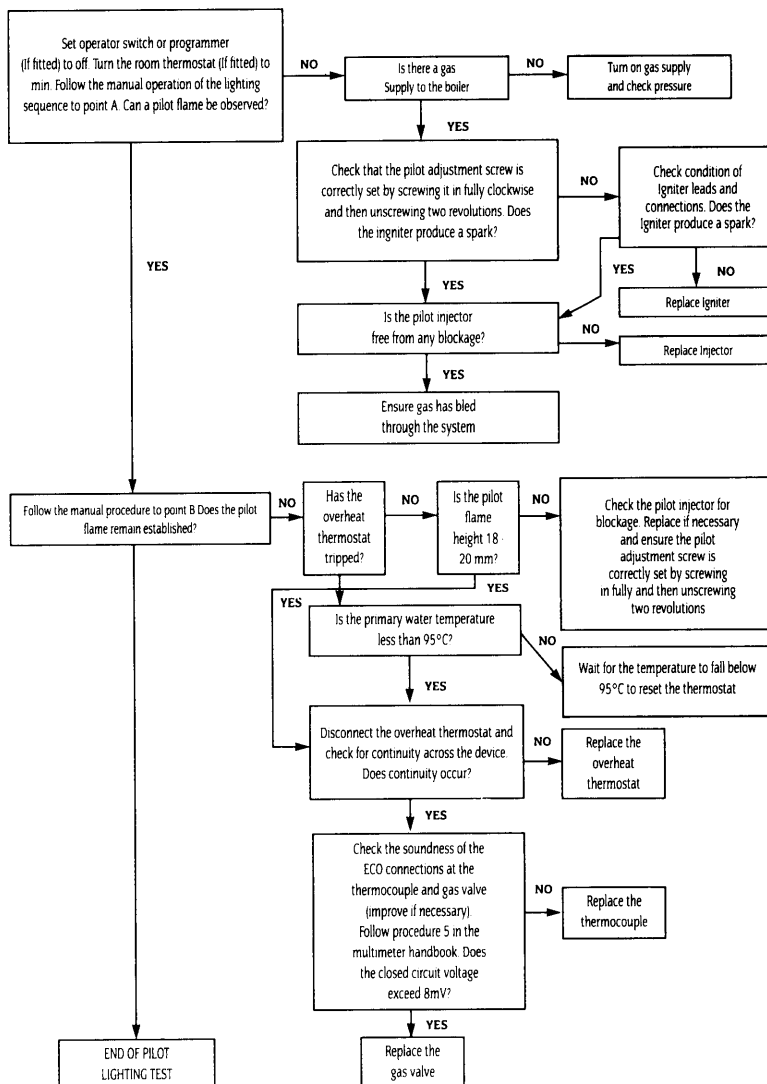

START OF CENTRAL HEATING TEST

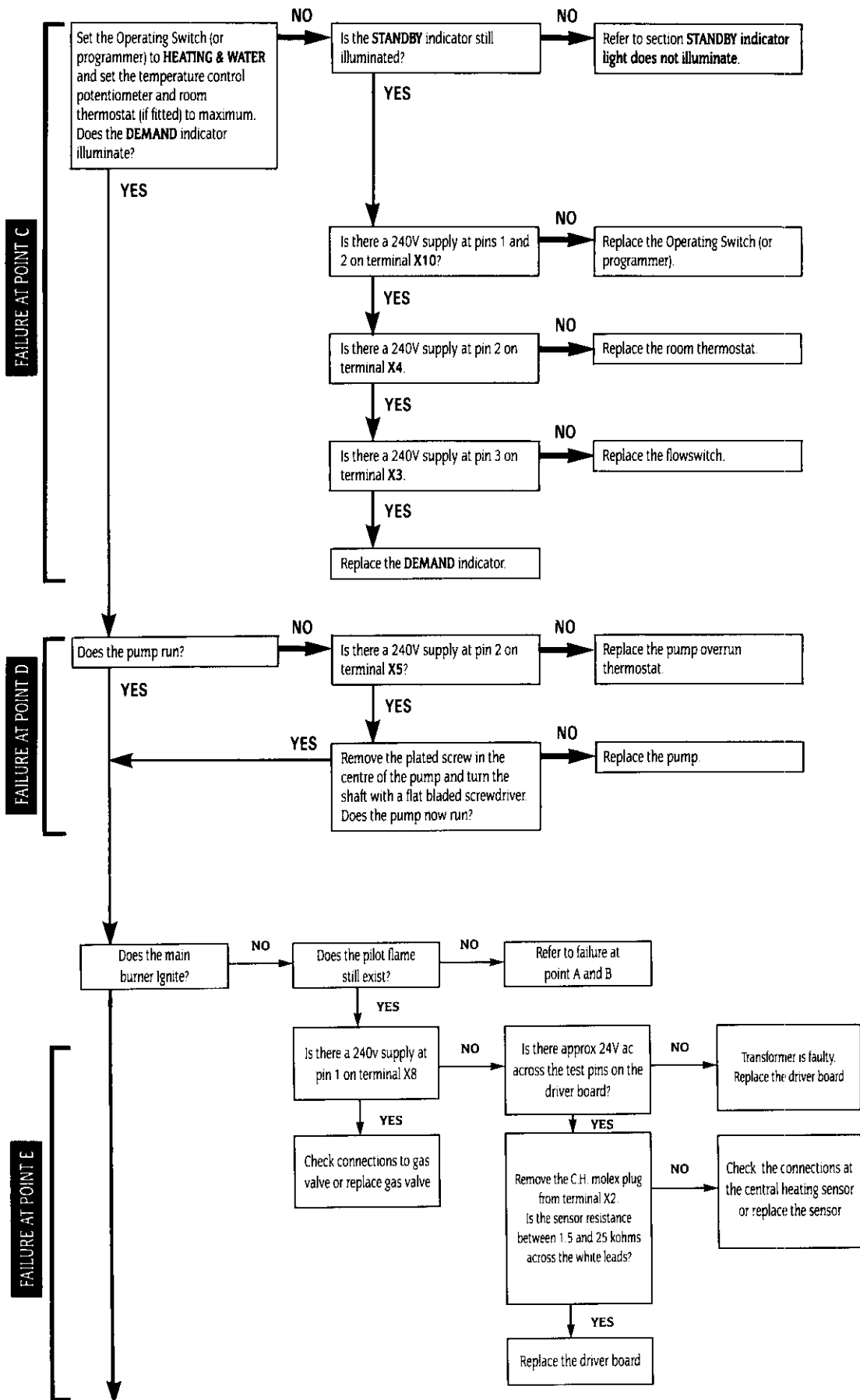

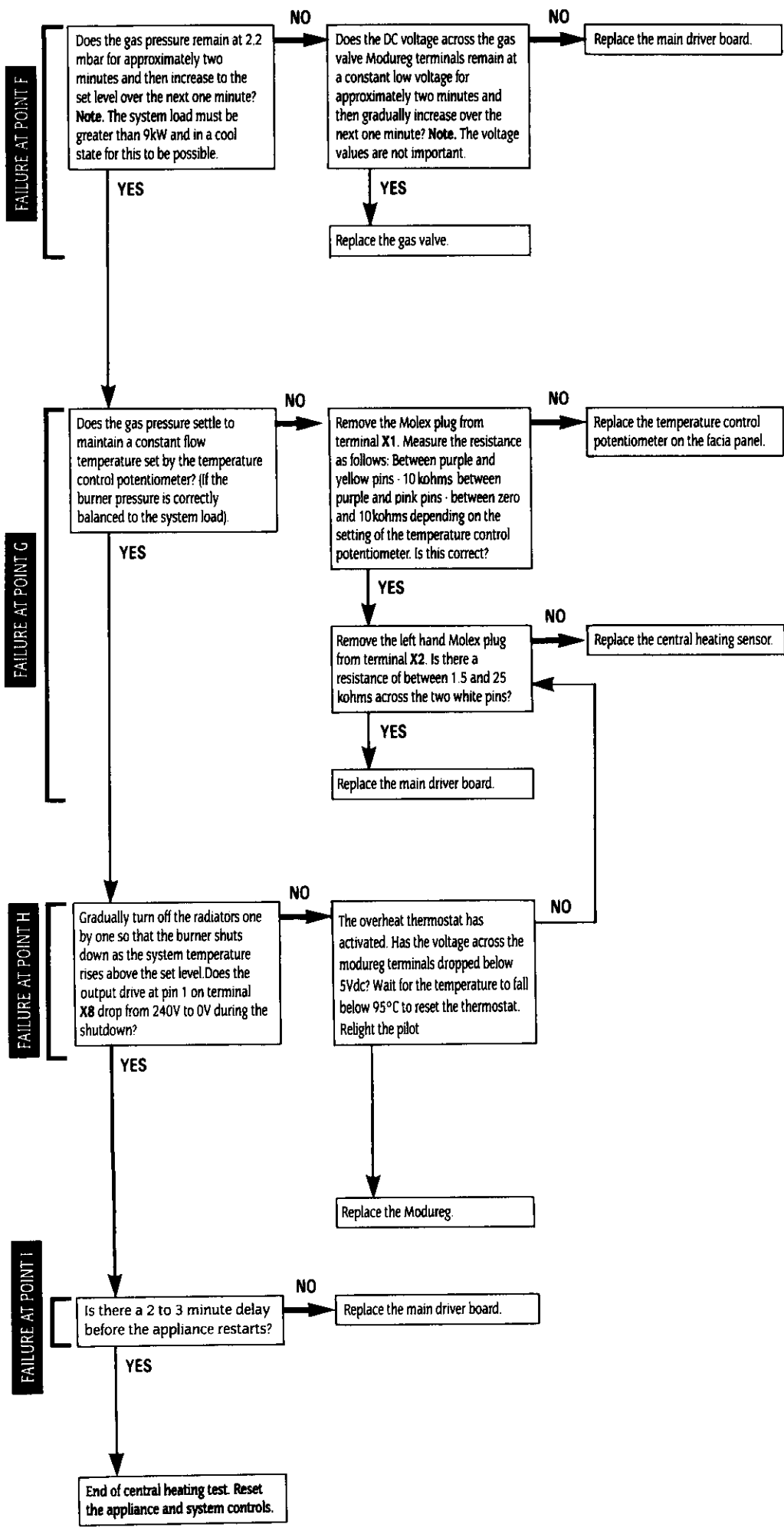

START OF DOMESTIC HOT WATER TEST

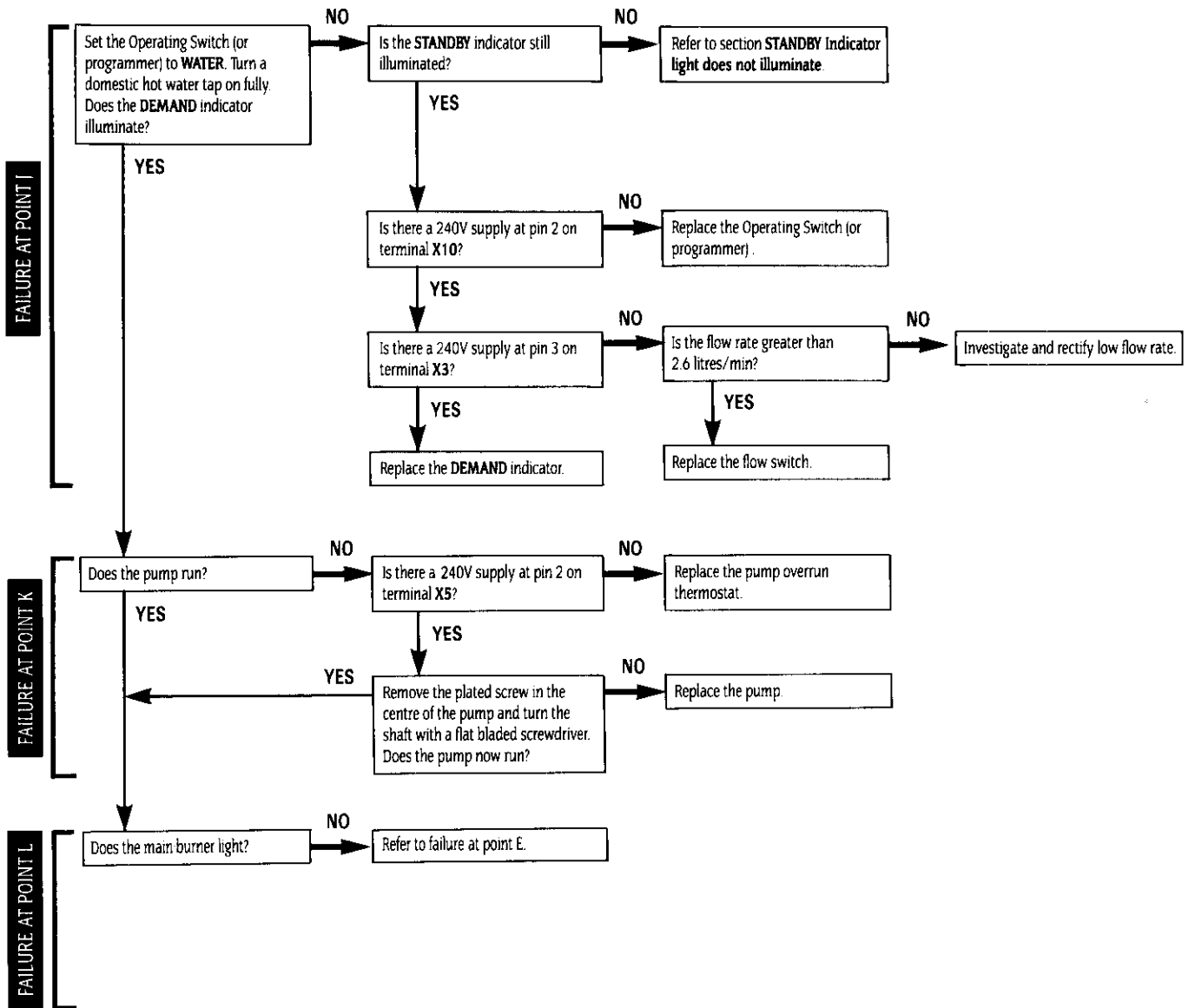

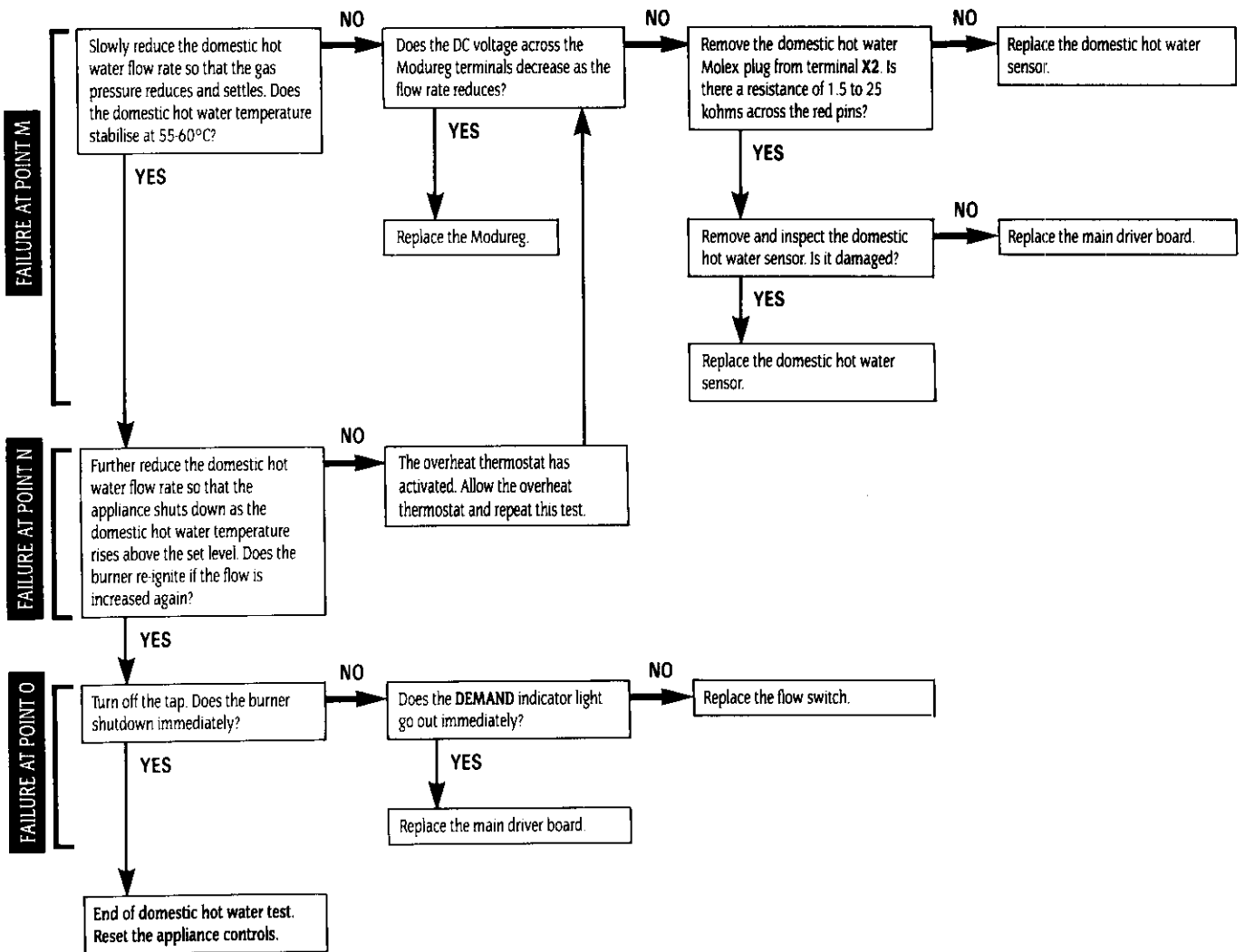

**START OF PUMP OVERRUN TEST**

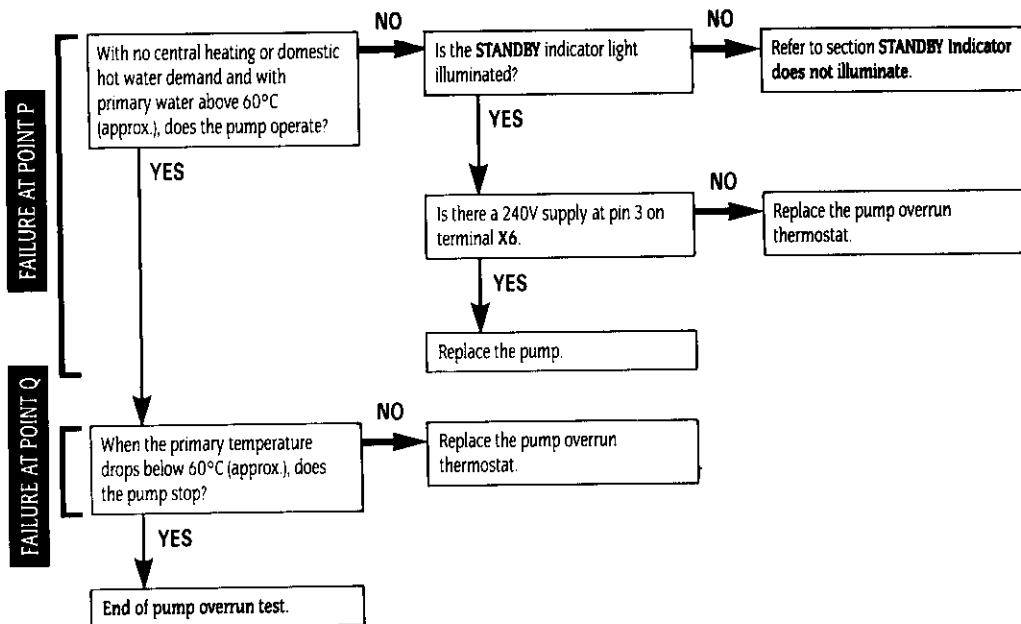

**OVERHEAT PROTECTION TEST**

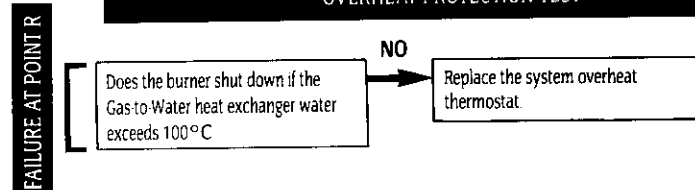



PAGE 3:

**2.12 SAFETY CONSIDERATIONS**

The appliance must not be operated with the flue safety thermostat put out of operation. Unauthorised interference with this device can lead to serious consequences for the occupants of the building in which this boiler is located.

PAGE 6:

**6.6 FLUE SAFETY THERMOSTAT**

A flue safety thermostat is fitted into the draught diverter to shut off the main burner to limit the quantity of combustion products that would be evacuated from the boiler in the event of a blockage, or part blockage occurring in the flue system, or excessive down-draught.

The flue safety thermostat should only be located on the mounting bracket fitted for correct operation. Only replacements from Worcester Bosch should be fitted to ensure correct operation.

In the event of a shutdown by the flue safety thermostat it will be possible to reset it within 30 seconds.

In the event of repeated shut down of the boiler by the flue safety thermostat it will be necessary to take appropriate action to remedy the discharge fault and it is necessary to carry out an operational test after each intervention of the device.

PAGE 24:

**28 FLUE SAFETY THERMOSTAT**

Check that the electricity supply to the appliance is turned off.

Remove the right-hand side cabinet panel as described in Section 14.3(a).

Lower the facia panels described in Section 14.3(c).

Pull off the electrical connections, release the trip switch from the top of the electrical control box by removing the retaining nut. At the draught diverter, release the sensor from the plastic retaining clips.

When fitting the replacement thermostat, carefully unwind the side of the capillary sense line closest to the sensor so that the spare coils remain close to the switch. When fitting the sensor, ensure the sensor line is firmly engaged upon the plastic retainers and the sense line does not come into contact with the metal of the draught diverter and the sides or edges of the inner metal cabinet.

Reassemble the appliance in the reverse order – EXCEPT – reconnect the piezo spark lead to the piezo spark device before refastening the right-hand side panel.

PAGE 10: WIRING DIAGRAM

Fig. 7. Wiring Diagram – Control panel and facia.

(All components shown viewed from front of appliance)

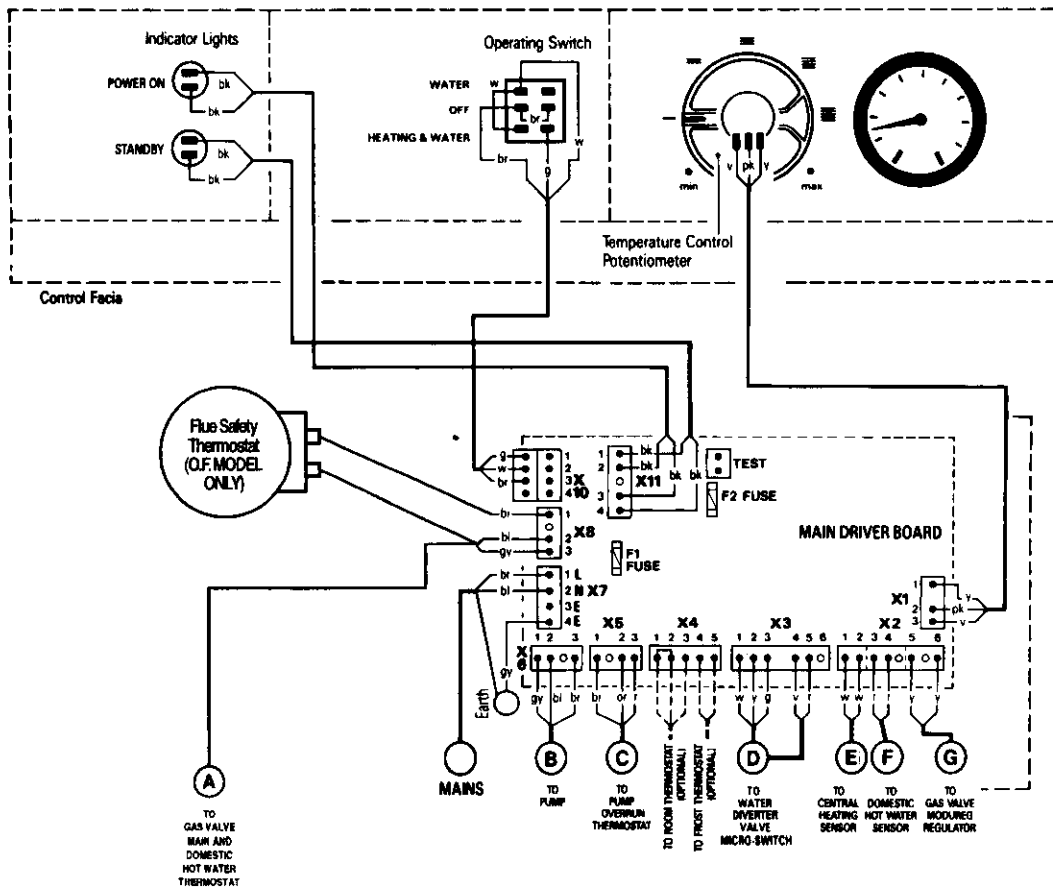

**COLOUR CODE**  
 br—brown bl—blue gy—green and yellow bk—black or—orange  
 r—red w—white y—yellow g—grey v—violet pk—pink

PAGE 25: SHORT PARTS LIST

GC No.	Part	Manufacturer's Reference	No.	WHS Part No.
E00-770	Flue Safety Thermostat	Ranco LM7-P5093	1	8 716 142 306

Fig. 9. Functional flow diagram.

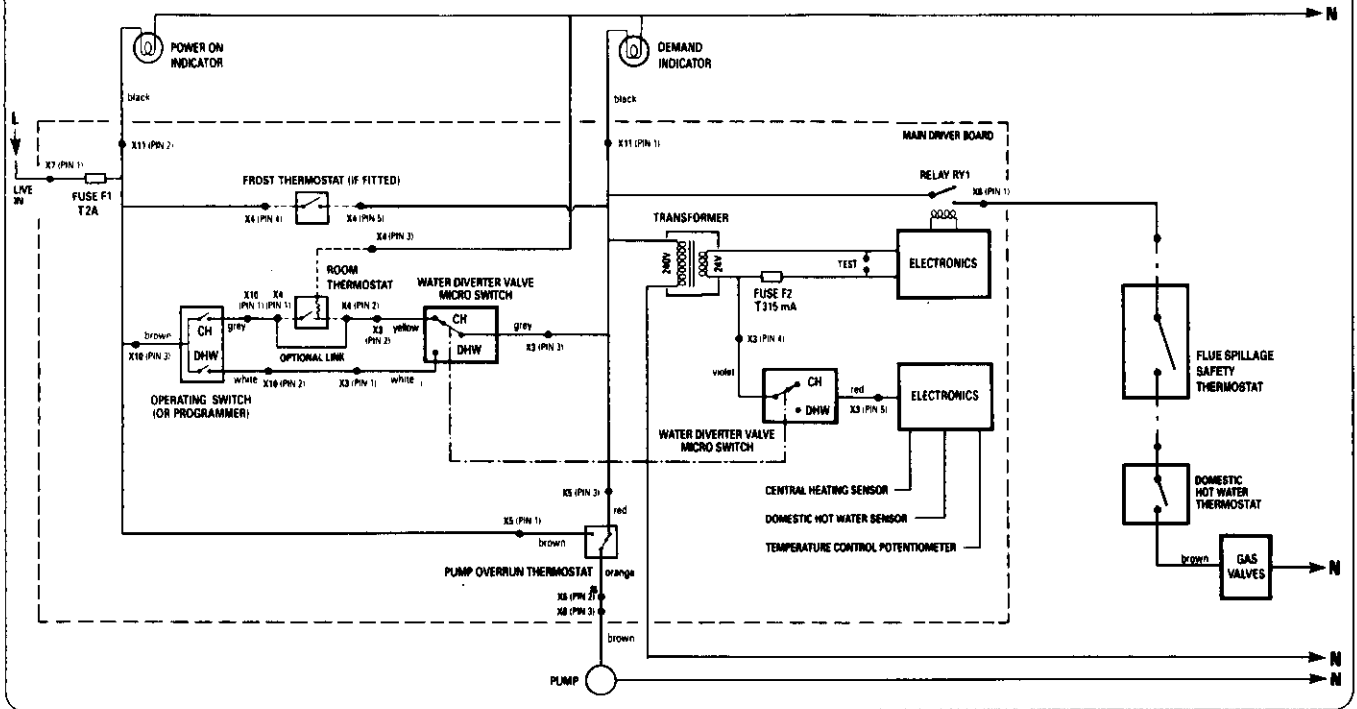

PAGE 24: FIG. 32. FLUE SENSOR FITTING. (Additional figure).

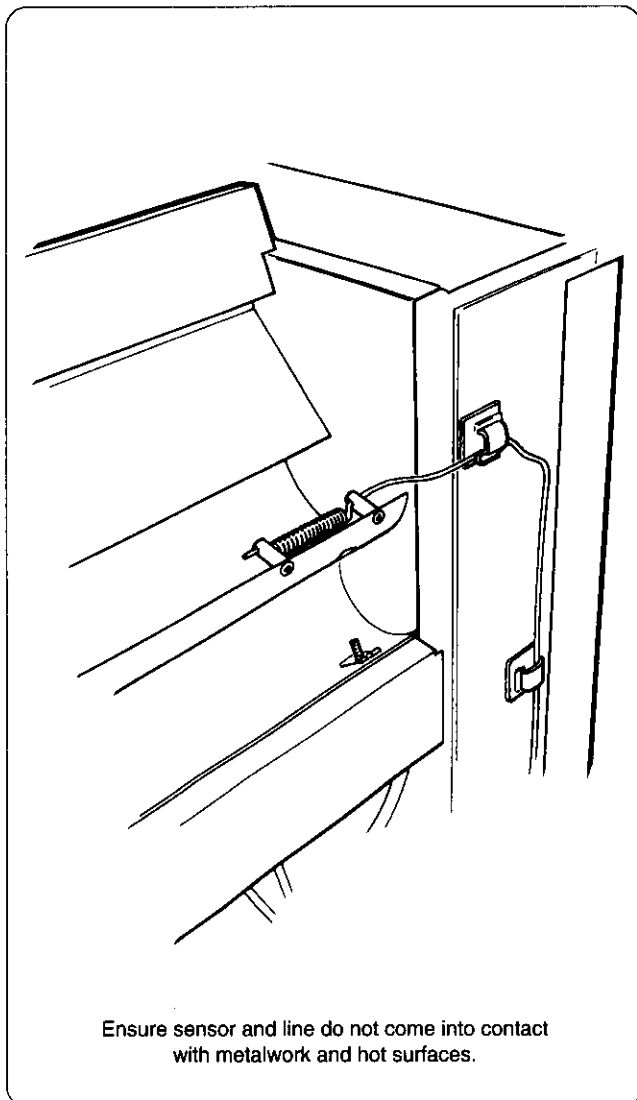

PAGE 27: ADDITION TO OPERATIONAL FLOW DIAGRAMS.

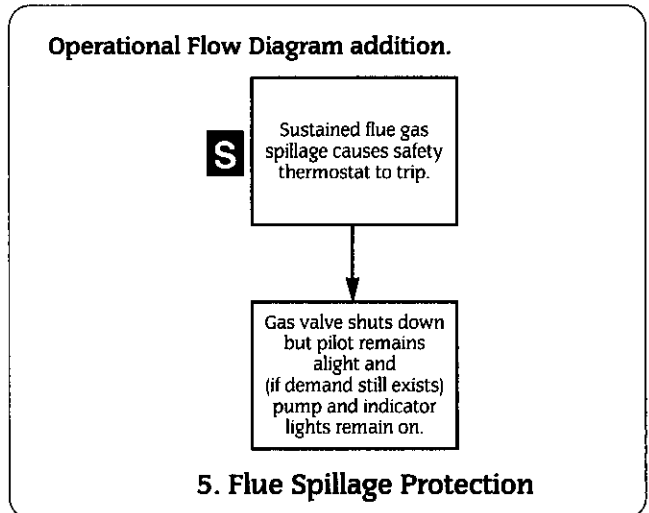

PAGE 33: ADDITION TO FAULT FINDING.

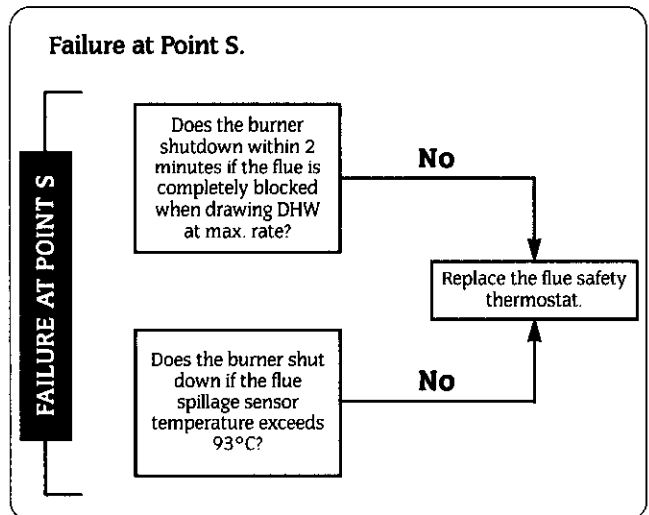

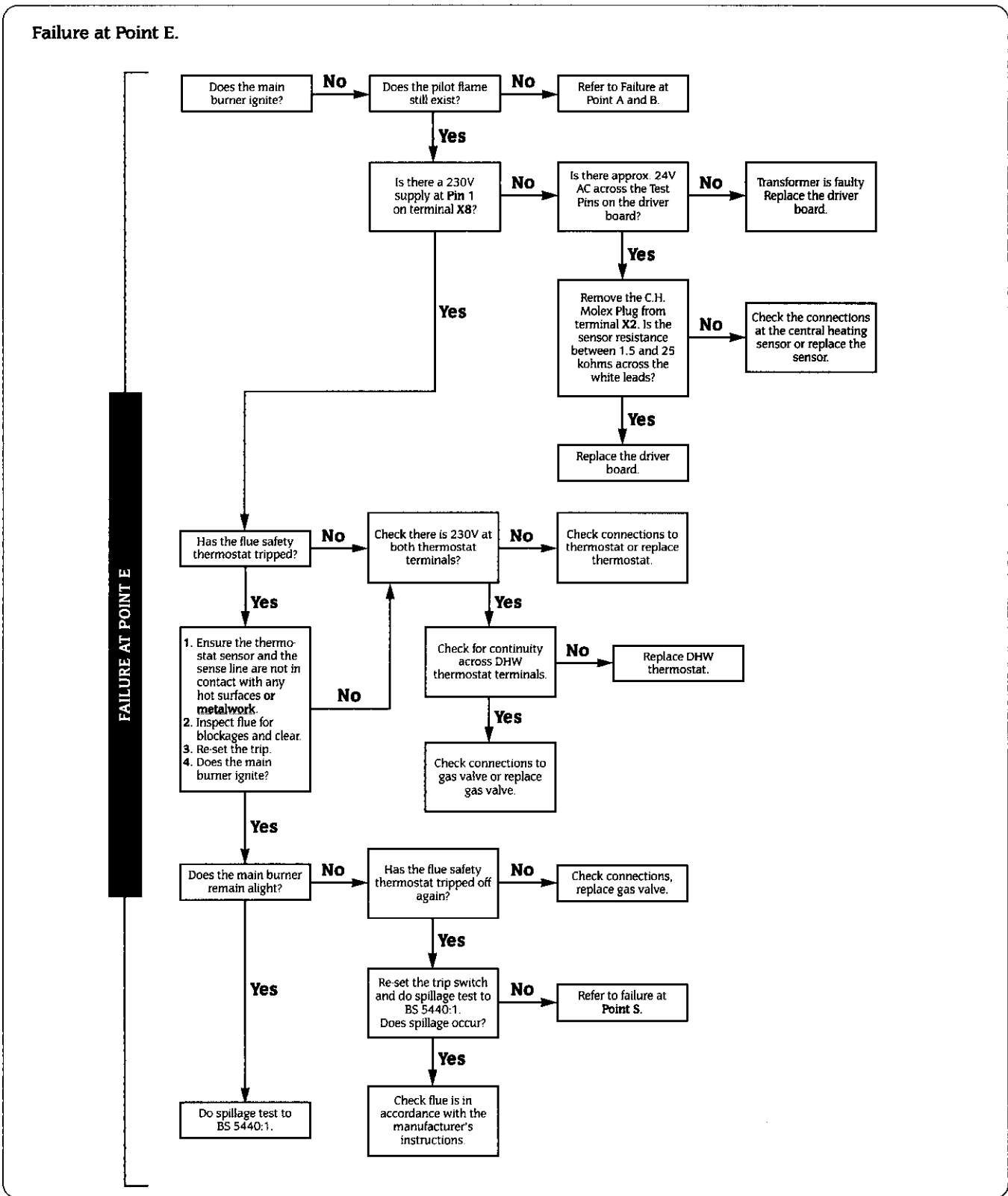

Worcester Heat Systems Limited, Cotswold Way, Warndon, Worcester WR4 9SW.  
Telephone: (01905) 754624. Fax: (01905) 754619.  
Technical Helpline (0990) 266241.

This booklet is accurate at the date of printing but will be superseded and should be disregarded if specifications and/or appearances are changed in the interests of continued improvement.

All goods sold are subject to our official Conditions of Sale, a copy of which may be obtained on application.

**PUBLICATION 8 716 145 052 – ISSUE 1 DECEMBER 1996**



*Worcester Heat Systems Limited, Cotswold Way, Warndon, Worcester WR4 9SW.  
Telephone: (01905) 754624 Fax: (01905) 754619*

---

This booklet is accurate at the date of printing but will be superseded and should be disregarded if specifications and/or appearances are changed in the interests of continued improvement.

All goods sold are subject to our official Conditions of Sale, a copy of which may be obtained on application.

**PUBLICATION ZKLIT504 – ISSUE 2 NOVEMBER 1995**